

Thermal Cutoff ST3812 214°C 10A

PSE License No.: JET1345-32001-2012

1. Construction and Dimensions

Regarding to "L" Dimension

ST3812 = 19mm (Normal Length)

ST3812 -L = 35mm (Long Length)

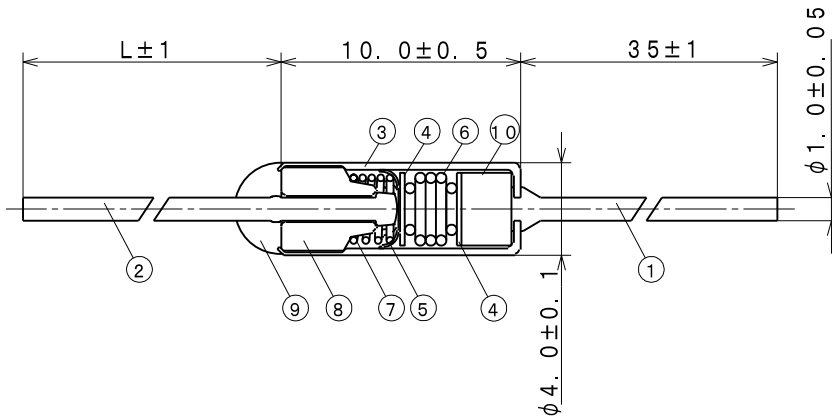

	Name of parts	Material
1	Lead wire A	Sn-plated Cu wire
2	Lead wire B	Ag-plated Cu wire
3	Case	Ag-plated Cu
4	Ring washer	Cu
5	Moving contact	Ag-alloy
6	Spring A	Stainless-Steel
7	Spring B	Stainless-Steel
8	Bushing	Ceramic
9	Sealant	Epoxy resin
10	Thermal element	Organic compound

2. Temperature and Electrical rating.(Resistive load)

Basic Model No.	Tf (°C)	Th (°C)	Tm (°C)	Function Temperature (°C)	Rated Voltage (V)	Rated Current (A)	Certifications				
							PSE	UL	C-UL	VDE	CCC
ST 3812	—	—	—	214 +2 -2	AC250V	10A	✓				

※ "✓" = Approved

※ Please note that the maximum continuous use temperature is less than 155°C.

※ Product No. is composed by Basic Model No. + Wire Length Symbol + Function Temperature (°C)

※ Rated Current.

For example, =ST3812 -L 214°C 10A (Long Length)

=ST3812 214°C 10A (Normal Length)

3. Test

3-1. Calibration verification test

(1) After the thermal cutoff is tested in accordance with paragraphs 3.1.(2) and 3.1.(3), the observed functioning temperature of each thermal cutoff shall not differ by more than plus 0°C and minus 10°C from the rated functioning temperature.

(2) Equilibrium conditions of oven temperature prior to the start of the test are to be established approximately 10°C below the rated functioning temperature for 2 hours or more. The temperature in the oven is then to be increased at a rate of 0.25-0.50°C per minute until all thermal cutoff open.

(3) Opening of a thermal cutoff is to be determined by a detecting current through the thermal cutoff not more than 0.01 amperes.

3-2. Overload test

(1) After the thermal cutoff is tested in accordance with paragraph 3.2.(2) and 3.2.(3). There shall be no damage to the integral leads of a thermal cutoff. The case of an enclosed element shall remain intact.

(2) The test current is 1.5 times rated current. The test potential is 250V.

(3) Thermal cutoff is to be placed in test oven that has been stabilized at 10°C below the rated functioning temperature and then the temperature of oven is to re stabilize. The thermal cutoff is then to be energized and the oven temperature is to increase at the rate of $2\pm 1^\circ\text{C}$ per minute and the test is to be continued until the thermal cutoff function.