

600 Amp AC Clampmeter User Manual

TECHNICIAN





600 Amp AC Clampmeter User Manual

Thank you for purchasing this 600 Amp AC Clampmeter. The reading range of up to 600A makes this clampmeter ideal for electrical fitters and contractors working with high currents. Autoranging by default, the clampmeter also features true RMS for accurate readings. Utilise the data hold and relative measurement modes to log and compare data. The backlight will assist you to view various readings in low light conditions.

Please familiarise yourself with the functions of the clampmeter before use. We recommend retaining this manual for ease of reference.

- Improper use of this meter can cause damage, shock, injury or death.
- Always remove the test leads before replacing the battery or fuses.
- Before using the meter, please inspect the condition of the test leads and the meter itself for any damage. If damage is present, please discontinue use.
- Do not measure voltage if the voltage on the terminals exceeds 600V above earth ground.
- Use great care if voltages are greater than 30VAC RMS. Anything above this is considered a shock hazard.
- Do not apply voltage to the meter when the resistance is selected.
- Do not exceed the maximum limits of the input values shown in the specification tables on pages 10-12 of this manual.
- Remove the batteries from the meter if it will be unused for an extended period of time.

FUNCTIONS	
Max. Display	4000 Count
Basic Accuracy	0.5%
DC Voltage Range	400mV - 600V
AC Voltage Range	400mV - 600V
AC Current Range	40A - 600A
Resistance	400Ω - 40MΩ
Capacitance	10nF - 100mF
Diode Test	Yes
Continuity	Yes
Frequency	10Hz - 10MHz
NCV (Non-Contact Voltage) Detection	Yes
Duty Cycle	Yes
Temperature	-20°C - 1000°C
Relative Measurement	Yes
Data Hold	Yes
Autoranging	Yes
Auto Power Off	Yes



The battery compartment is at the rear of the multimeter.

FUNCTIONS	
NCV Detection	Move the rotary switch to NCV position, hold the meter once detect the voltage, meter will be alarmed and LED flash
Current Clamp	Clamp the cable once measuring the current, the current reading will be displayed in LCD
Flash Light	Turn on the flash light and the light bulb will be lighted
NCV Indicator	Once NCV function detect the voltage, the LED indicator will be twinkled
Data Hold	Push this button to hold the readings in LCD, push one more time to exit the data hold function
Clamp Opening Trigger	The max. jaw opening size is 23mm
Rotary Switch	Move the rotary switch for selecting proper range and function
Backlight Button	Push the button to activate the LCD backlight, push one more time to exit. Once rotary switch move to current measurement range, push this button can also turn on the flash light
LCD Display	Readings and measurements taken by the clampmeter appear in this area.
Input Jacks	<ul style="list-style-type: none"> • V/TEMP: Positive input jack • COM: Negative input jack

FUNCTION BUTTONS	
SEL	Push SEL to shift AC/DC, °C / °F, resistance, diode & continuity test
RAN	Push this button to switch proper range under voltage and resistance measurement mode
HOLD	Push this button to hold the readings in LCD, press again to exit the data hold function
Hz/%	Under AC voltage measurement, press Hz/% to selection function from voltage frequency to duty cycle
REL	Under AC current measurement hold the button down to activate inrush/surge current measurement. Hold button down again to exit the function.

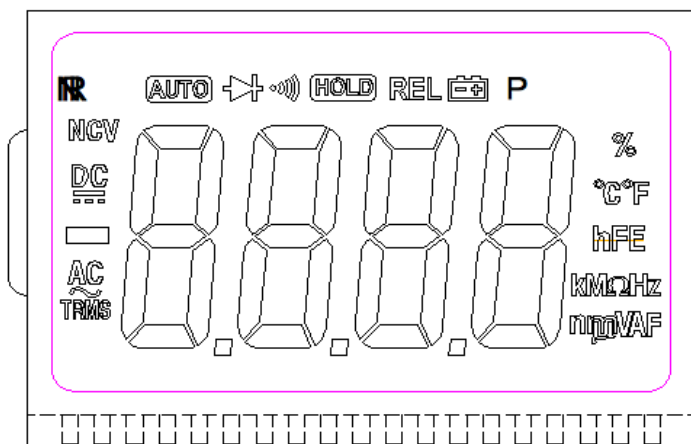

SYMBOL	DESCRIPTION	SYMBOL	DESCRIPTION
HOLD	Data Hold		Low Voltage Indication
	Diode Test		Continuity
NCV	Non-Contact Voltage Detection	INR	Inrush Current
mV V	Unit of Voltage	uA mA A	Unit of Current
Hz KHz MHz	Unit of Frequency	pF nF uF mF	Unit of Capacitance
DC	Direct Current	AC	Alternating Current
°F	Fahrenheit Temperature	°C	Centigrade Temperature
%	Duty Cycle Measurement	REL	Relative Value Measurement
TRMS	True RMS Measurement		

OPERATING INSTRUCTIONS

NOTE: Read and understand all Warning and Caution statements in this operation manual prior to using this meter. Set the rotary switch to the OFF position when the meter is not in use.

CURRENT MEASUREMENTS

 **WARNING:**

- Disconnect the test leads before making clamp measurements
 - To avoid electrical shock and/or damage to the meter, do not attempt to take any voltage measurement that might exceed 600V
- 1) Set the rotary switch to proper current range, select the correct range based on measurement
 - 2) Press the clamp opening trigger to open the jaws and fully enclose one conducting wire
 - 3) Read the measured current value in the LCD display
 - 4) If display shows "OL", means overload, should select the higher range of measurements

DC VOLTAGE MEASUREMENTS

 **WARNING:**

- The max. input DC voltage is 600V DC, to avoid electrical shock and/or damage the meter, do not attempt to take any voltage measurement that might exceed 600V DC
- 1) Set the rotary switch to the **V** \cong position.
 - 2) Insert the black test lead banana plug into **COM** jack, insert the red test lead banana plug into **INPUT** jack.
 - 3) Touch the black test probe tip to the negative side of the circuit; touch the red test lead probe tip to the positive side of circuit.
 - 4) Read the voltage value in the display.

NOTE: Unstable display may occur, especially at the low voltage range measurement (like 200mV range), even no test leads insert at input terminals, and it is the normal situation and not influences the accuracy.

AC VOLTAGE MEASUREMENTS

WARNING:

- The max. input DC voltage is 600V DC, to avoid electrical shock and/or damage the meter, do not attempt to take any voltage measurement that might exceed 600V DC
- 1) Set the function switch to the V_{\approx} position.
 - 2) Insert the black test lead banana plug into **COM** jack, insert the red test lead banana plug into **INPUT** jack.
 - 3) Touch the black test probe tip to the negative side of the circuit; touch the red test lead probe tip to the positive side of circuit.
 - 4) Read the voltage value in the display.

NOTE: Unstable display may occur, especially at the low voltage range measurement (like 2V range), even no test leads insert at input terminals, and it is the normal situation and not influences the accuracy.

RESISTANCE MEASUREMENT

WARNING:

- To avoid electric shock, disconnect power to the unit under test and discharge all capacitors before taking any resistance measurements
- 1) Set the function switch to $\rightarrow \Omega$ position and press the **SEL** button to select the Ω range
 - 2) Insert the black test lead banana plug into **COM** jack, insert the red test lead banana plug into **INPUT** jack.
 - 3) Touch the black test probe tip to one side of the resistance of under test; touch the red test probe tip to the other side.
 - 4) Read the resistance value in the display.

DIODE TEST



WARNING:

- To avoid electric shock, disconnect power to the unit under test and discharge all capacitors before taking diode test
- 1) Set the function switch to $\rightarrow \Omega$ position and press the **SEL** button to choose diode test mode \rightarrow
 - 2) Insert the black test lead banana plug into **COM** jack, insert the red test lead banana plug into **INPUT** jack.
 - 3) Place the red test lead on the anode of diode and black test lead on the cathode of diode.
 - 4) The meter will show the approx. forward voltage of diode. Reverse voltage will indicate **OL**.

CONTINUITY CHECK



WARNING:

- To avoid electric shock, disconnect power to the unit under test and discharge all capacitors before taking continuity check
- 1) Set the function switch to $\rightarrow \Omega$ position and press the **SEL** button to choose continuity check mode \rightarrow
 - 2) Insert the black test lead banana plug into **COM** jack, insert the red test lead banana plug into **INPUT** jack.
 - 3) Touch the test probe tips across the circuit or component under test.
 - 4) If the resistance is $<30\Omega$, the audible signal will be sounded.

TEMPERATURE MEASUREMENT

- 1) Set the function switch to $^{\circ}\text{C}$ $^{\circ}\text{F}$ position, the value of environmental temperature shows in display. Press **SEL** button to shift $^{\circ}\text{C}$ mode or $^{\circ}\text{F}$ mode.
- 2) Insert the red terminal of temperature probe into the **INPUT** jack, black terminal into **COM** jack, place the temperature probe tip where needed to measure.
- 3) Read the temperature on the display

RESISTANCE MEASUREMENT

WARNING:

Due to external interference source, this function may cause wrong voltage detection, the detection result is for reference only.

Set the function switch to NCV position, contact the top part of meter with the circuit under test, the indicating LED will be flashed and audible signal will be sounded once detecting the voltage, the signal strength showed in LCD display.

NOTE:

- The detection result is for reference, do not determine the voltage by NCV detection ONLY
- Detection may interfere by socket design, insulation thickness and other variable conditions
- The external interference sources, such as flashlight, motor, etc, may cause the wrong detection

LINE (LIVE WIRE RECOGNITION) TEST

Set the rotary switch to LINE position, connect the black test lead to COM jack and red test lead to $V\Omega$ jack, hold the insulation part of black test lead and not put into circuit under measurement; contact the red test lead to live wire, the buzzer of meter will be activated and red LED will be flickered, when the red test lead connect the earth line, the buzzer does not sound and LED will not flicker.

NOTE: When the circuit is in serious leakage (approx. over 15V), the red test lead even contact earth line, the buzzer of meter will be sounded and LED will be flickered.

CAPACITANCE MEASUREMENT

WARNING:

- To avoid electric shock, disconnect power to the unit under test and discharge all capacitors before taking capacitance measurement.
- 1) Set the rotary switch to $\Omega_{\rightarrow+}$ position and press the **SEL** button to choose $\rightarrow+$ mode.
 - 2) Insert the black test lead banana plug into **COM** jack, insert the red test lead banana plug into **INPUT** jack.
 - 3) Touch the test probe tips across the capacitance under test.
 - 4) Read the capacitance value in the display.

MEASUREMENT SPECIFICATIONS

Accuracy: \pm (%readings + digit), warranty period: 12 months)

The following guide is based on an environmental temperature of 18-28°C and humidity <80%.

DC VOLTAGE

RANGE	RESOLUTION	ACCURACY
400mV	0.1mV	\pm (0.5% reading + 3 digits)
4V	0.001V	\pm (0.8% reading + 5 digits)
40V	0.01V	
400V	0.1V	
600V	1V	\pm (1.0% reading + 5 digits)

Input impedance: 10M Ω ; Max. input voltage: 600V DC / 600V AC RMS

AC VOLTAGE

RANGE	RESOLUTION	ACCURACY
400mV	0.1mV	\pm (1.0% reading + 10 digits)
4V	0.001V	\pm (1.0% reading + 5 digits)
40V	0.01V	
400V	0.1V	
600V	1V	\pm (1.2% reading + 5 digits)

Input impedance: 10M Ω ; Max. input voltage: 600V DC / 600V AC RMS

Frequency response: TRMS40Hz-1kHz

AC CURRENT

RANGE	RESOLUTION	ACCURACY
40A	0.01A	\pm (2.5% reading + 10 digits)
400A	0.1A	
600A	1A	



Frequency response: TRMS 40Hz-1kHz

RESISTANCE

RANGE	RESOLUTION	ACCURACY
400Ω	0.1Ω	±(1.0% reading + 10 digits)
4kΩ	0.001kΩ	±(0.8% reading + 5 digits)
40kΩ	0.01kΩ	
400kΩ	0.1kΩ	
4MΩ	0.001MΩ	
40MΩ	0.01Ω	±(2.0% reading + 10 digits)

Overload protection: 250V DC or 250V AC RMS

DIYODE AND CONTINUITY

RANGE	FUNCTION
	Display approximate forward voltage of diode, reverse shows OL
	Built-in buzzer will be sounded if resistance is less than 30Ω

CAPACITANCE

RANGE	RESOLUTION	ACCURACY
10nF	0.01nF	±(4.0% reading + 25 digits)
100nF	0.1nF	±(4.0% reading + 15 digits)
1μF	0.001μF	
10μF	0.01μF	
100μF	0.1μF	
1mF	1μF	±(5.0% reading + 25 digits)
10mF	10μF	
100mF	100μF	

Overload protection: 250V DC or 250V AC RMS

FREQUENCY

RANGE	RESOLUTION	ACCURACY
10Hz	0.01Hz	±(0.5% reading + 2 digits)
100Hz	0.1Hz	
1kHz	0.001kHz	
10kHz	0.01kHz	
100kHz	0.1kHz	
1MHz	0.001MHz	
10MHz	0.01MHz	

Overload protection: 250V DC or 250V AC RMS

TEMPERATURE

RANGE	-20°C - 1000°C	
Resolution	1°C	
Accuracy	-20°C - 0°C	±(5% reading + 4 digits)
	0°C - 400°C	±(2% reading + 3 digits)
	400°C - 1000°C	±(3% reading + 3 digits)
RANGE	0°F - 1800°F	
Resolution	1°F	
Accuracy	-0°F - 50°F	±(5% reading + 4 digits)
	50°F - 750°F	±(2% reading + 3 digits)
	750°F - 1800°F	±(3% reading + 3 digits)

Overload protection: 250V DC or 250V AC RMS

MAINTENANCE



WARNING:

- To avoid electric shock, disconnect the test leads from any source of voltage before removing the back cover or the battery or fuse covers
- To avoid electric shock, do not operate the meter until the battery and fuse covers are in place and fastened securely

CLEANING AND STORAGE

Periodically wipe the case with a damp cloth and mild detergent, do not use abrasives or solvents. If the meter is not be used for a long time, remove the battery and store it separately.

BATTERY INSTALLATION

To avoid the false readings, replace the battery as soon as the battery indicator appears.

- 1) Turn power off and disconnect the test leads from the meter.
- 2) Open the rear battery cover by using screwdriver.
- 3) Insert the battery into battery holder, observing the correct polarity.
- 4) Put the battery cover back in place, secure with the screws.

SPECIFICATIONS

Operating Temperature:	0~40°C
Operating Humidity:	< 80%RH
Storage Temperature:	-10°C~60°C
Storage Humidity:	< 70%RH (Remove Battery)
Max Input Voltage	600VRMS
Measuring Principle	Double Integral A/D Conversion
Measurement Rate:	2 per second, nominal
Display	3 3/4 LCD display, max. reading 3999
Range Selection	Auto Range Selection
Over Range Indication	"OL"
Power Supply:	3 x AAA
Clamp Size:	23mm opening (approx)
Dimensions:	194(H) x 72(W) x 35(D)mm
Weight:	230g (including battery)

BOX CONTENTS

1 x Clampmeter
1 x Test Leads
1 x Carry Case
1 x Temperature Probe
1 x User Manual

WARRANTY

This product is protected by a lifetime warranty (from the date of purchase) covering all product manufacturing defects/faults that may occur within this timeframe. This warranty does not cover damage caused by neglect, misuse, contamination, alteration, accident or abnormal conditions of operation or handling, including failures caused by use outside of the product's specifications, or the normal wear and tear of mechanical components.

In the event that you suspect your product is defective/faulty, cease using the product when the suspected defect/fault arises and return the product along with proof of purchase to the place of purchase or distributor for assessment. Distributor contact details are available below.

If the assessment concludes that the product is indeed defective/faulty, the product will either be repaired or replaced at no cost to you.

Our goods come with guarantees that cannot be excluded under the Australian Consumer Law. You are entitled to a replacement or refund for a major failure and compensation for any other reasonably foreseeable loss or damage. You are also entitled to have the goods repaired or replaced if the goods fail to be of acceptable quality and the failure does not amount to a major failure.

Distributed by:
TechBrands by Electus Distribution Pty. Ltd.
320 Victoria Rd, Rydalmere
NSW 2116 Australia

Ph: 1300 738 555
Int'l: +61 2 8832 3200
Fax: 1300 738 500

www.techbrands.com