

protech

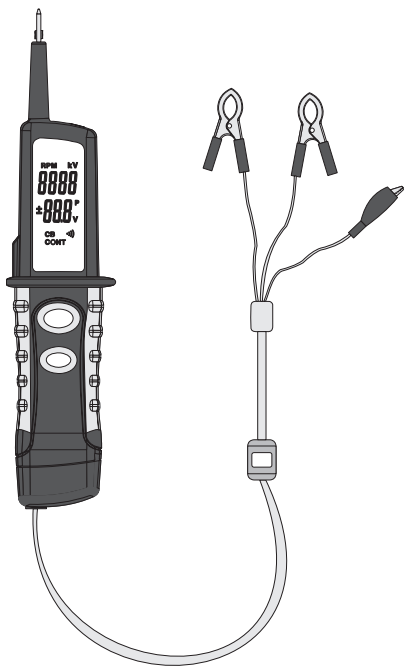

Automotive Multi-Function Circuit Tester
with LCD
QM1494
User Manual

Contents

1. Introduction	4
2. Illumination	4
3. Important	5
4. Warning	5
5. Getting to know your tester	5
6. Mode instruction	6
7. Power Connection	8
8. Self-Test	8
9. Polarity Test	8
10. Conductivity Test	9
11. Activate the components with automotive electrical system disconnected	10
12. Activate components with positive voltage only	11
13. Important	11
14. Important	12
15. Activate the components with negative voltage only	12
16. Important	12
17. Trailer Light Test	13
18. Voltage Test	14
19. Locate missing cylinders	14
20. Measuring the frequency of the high-tension ignition pulses	14
21. Peak Detection	18

1. Introduction

This is an equipment used to the automotive electrical system within 12-24 volts. In order to save the testing hours for the automotive electrical system. It is designed to testing the system without re-connection between the vehicle battery and the testing components, and it contains the following functions :

- Determine the polarity and circuit circumstance(short/open).
- Activating the components with positive or negative current without jumper wire
- Testing the voltage and continuity of the circuit .
- Illumination.
- Locate missing cylinders.
- Measuring frequency of the high-tension ignition pulses and we could calculate the rotational speed of engine according to the measured frequency.
- Peak detection.
- Testing the voltage of the circuit and the voltage reading will be indicated on the LCD display within 1/10th of a volt.

Eventually, for the testing and safety purpose , this unit contains short-circuit protection , which can also check the ground connection without voltage drop tests. The short-circuit protection system contains the recoverable fuse, and so the technician will not waste the fuses during the testing . The extension cable with this unit is long enough for a technician to test the whole system for the vehicle ,therefore, the technician do not have to search for ground connection constantly.

2. Illumination

Since some of the testing circuit will be shadowed during the testing ,it provides the illumination for you convenience. The illumination will automatically turned on as the technician hook up it with vehicle battery.

3. Important

Please read the instruction before you start to use this instrument.

4. Warning

When current is provided to the unit ,spark may be occurred when the tip contacts with ground or certain circuits. Therefore please do not operating it with 110/220 volt house voltage as it is only for 12-24 volt systems.

5. Getting to know your tester

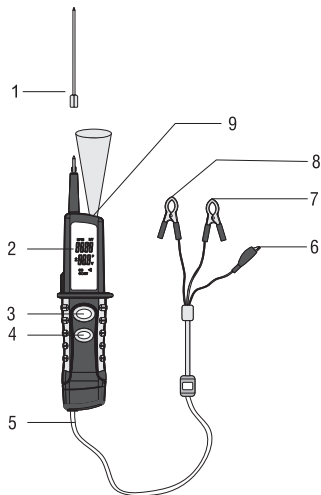

1. Test probe
2. LCD display reading
3. Auto test button
4. Polar switch
5. Test lead
6. Ground testing lead
7. Black power clip
8. Red power clip
9. Light

If you use the tester's "Polar switch "to test, please add extended-probe to the tester's probe .As shown in the figure For example:

- Activate the components with automotive electrical system disconnected
- Activate the components with positive voltage only
- Activate the components with negative voltage only
- Trailer light Test

Important

If the circuit breaker of the short circuit protection has tripped, please do not contact your hand to the probe and extended-probe immediately. Because the probe and extended –probe is very hot after the circuit breaker has tripped.

6. Mode instruction

The tester have four modes ,the four modes can be selected by depressing the mode select button and cycling through each one.

1. MODE

Voltage meter

Measuring range:

0v-60v

display

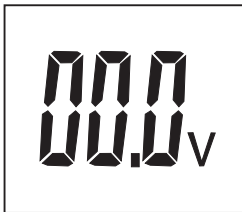

2. Locate missing
Cylinders



3. Measuring frequency
of the ignition pulses
The sign "HC" denotes "Hz"

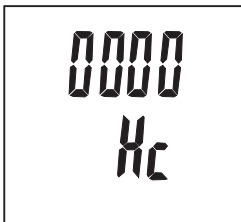

4. Peak Detection

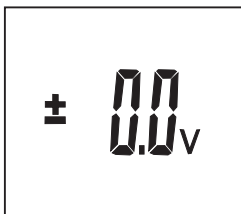

7. Power Connection

1. Hook up the black power clip to the negative of the vehicle battery .
2. Hook up the red power clip to the positive of the vehicle battery .

8. Self-Test

If the tester is working correctly ,the condition should be followed:

- Red LED should be on when the technician push the polar switch forward (toward the positive side).
- Green LED should be on when the technician push the polar switch backward. (toward the negative side).

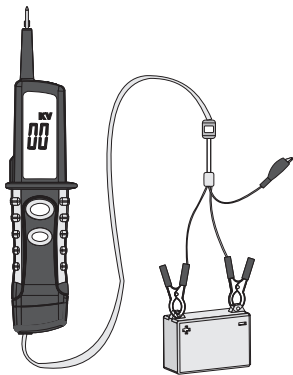

9. Polarity Test

- If the tester tip is contacting with positive pole, the red LED will be on.
- If the tester tip is contacting with negative pole, the green LED will be on.
- If the tester tip is contacting with open circuit, neither LED will be on .

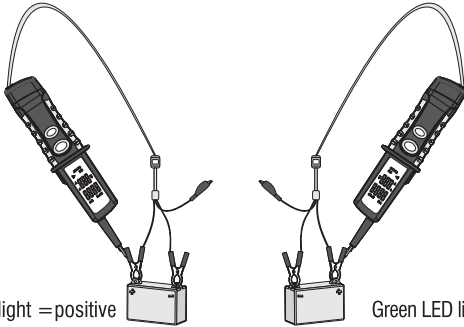

Red LED light = positive

Green LED lighting = negative

10. Conductivity Test

By using tester tip assisting with ground test lead, technician can test the conductivity between wires or components which has been disconnected from the vehicle electrical system .If the current is conductive between wires or components, the green LED should be on.

NO CONTINUITY

CONTINUITY

Green LED lighting = CONTINUITY

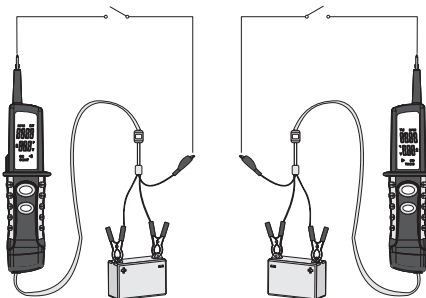

11. Activate the components with automotive electrical system disconnected

By assisting tester tip with the ground test lead, technician can activate the testing components with automotive electrical system been disconnected. This function can be used to test light, cooling fans, and fuel pumps etc. To do this, please follow the procedure:

1. Connect the ground test lead with the negative pole of the components
2. Contact the tester tip with the positive pole of the components. If the green LED is on ,it means the testing component is conductible .
3. As the green LED goes on ,please press the polar switch forward and then release it quickly. If the LED goes from green to red ,you may proceed further testing. If the green LED turns off and red LED doesn't turns on ,or if the circuit protection tripped, it means tester has overloaded. This may due to the following reasons:
 - The component is short circuit or it has been connected to the ground /negative pole directly.
 - The component is a high current component.

If the circuit breaker of the short circuit protection has tripped, it will auto-rest within no more than 60 seconds.

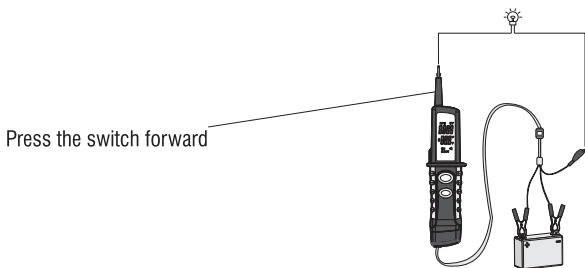

12. Activate components with positive voltage only

When technician tests the components, technician can use tester to provide positive voltage to the testing components. To do this, please follow the procedure:

1. Contact the tester tip with the positive pole of the components. If the green LED is on, it means the testing component is conductible.
2. As the green LED goes on ,please press the polar switch forward and then release it quickly. If the LED goes from green to red LED ,you may proceed further testing. If the green LED turns off and red LED doesn't turns on, or if the circuit breaker of the short circuit protection tripped, it means tester has overloaded. This may due to the following reasons:
 - The component is short circuit or it has been connected to the ground/negative pole directly.
 - The component is a high current component.

If the circuit breaker of the short circuit protection has tripped, it will auto-rest within no more than 60 seconds.

13. Important

Please operate this function with schematic and correct testing procedure because applying voltage arbitrarily may cause damage to components. Use tip to apply positive voltage , which can be helpful to diagnose the components.

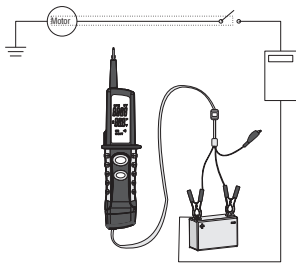

14. Important:

When applying current to the components, please push the switch before contact the tip with the components. In this case, the arcing will take place between the tip and the component instead of the switch. And so it can increase the life time of the switch.

15. Activate the components with negative voltage only

Apart from applying the positive voltage, technician can also use tester to provide negative voltage to the components. The procedures are as follow:

1. Contact the tester tip to the negative pole of the component; at this stage, the red LED should be on if the component working correctly.
2. Push the polar switch backward and release it quickly. If the LED goes from red to green, you may proceed further test. If the green LED goes off or the circuit breaker of the short circuit protection tripped, it means tester has overloaded. This may cause by the following reasons:
 - The component is short circuit or it has been connected to the ground/negative pole directly.
 - The component is a high current component.

If the circuit breaker of the short circuit protection has tripped, it will auto-rest within no more than 60 seconds.

16. Important

Please operate this function with schematic and correct testing procedure because applying voltage arbitrarily may cause damage to components. Use tip to apply negative, which can be helpful to diagnose the components

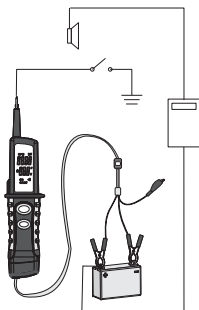

17.Trailer Light Test

To test trailer light, you need to follow the procedure:

1. Connect the ground test lead to trailer ground.
2. Probe the tip the outlet of the trailer, push the polar switch forward, then technician can diagnose the function of the trailer light.

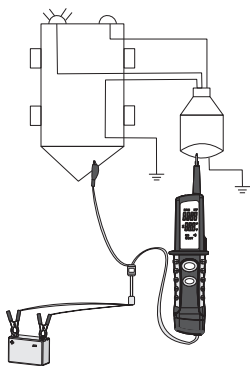

18. Voltage Test

Technician can also use tester assisting with ground to test the voltage of the circuit. However, during the voltage test, please do not push the polar switch.

1. If the probe tip is floating (not contacting a circuit), the red and green LED turn off.
2. If the tester contacts the probe tip to a positive circuit. The red positive sign “+” LED will light and the voltmeter displays the voltage reading within 1/10th of a volt.
3. If the tester contacts the probe tip to a negative circuit. The green negative sign “-” LED will light.

19. Locate missing cylinders

Placing the tester probe tip next to a sparking wire (DON'T probe it directly), through capacitive coupling, the tester can sense the high-tension ignition pulses at the same time display a voltage reading. By monitoring each plug wire in this way you can locate missing cylinders.

Warning: DO NOT CONTACT PROBE TIP DIRECTLY
TO THE SECONDARY IGNITION CIRCUIT.

20. Measuring the frequency of the high-tension ignition pulses

The tester can measure the frequency of the high-tension ignition pulses. Placing the tester probe tip next to a sparking wire (DO NOT probe it directly), through capacitive coupling, the tester can sense the high-tension ignition pulses at the same time display a frequency reading.

1. MEASURING METHOD

(1). -cylinder gasoline engine

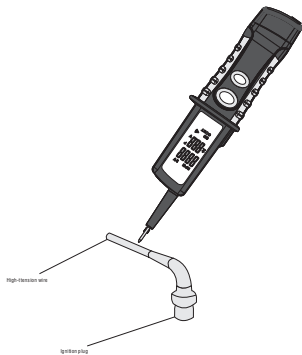

(2). Distributor type multi –cylinder gasoline engine

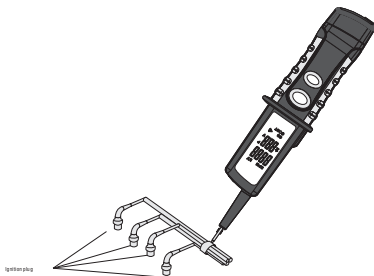

Where all the high-tension wires of cylinders are bundled together

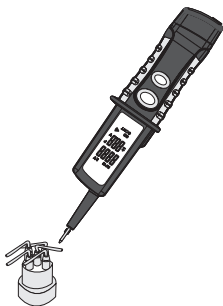

High-tension wire connecting distributor and ignition coil.

As shown in the figure A,B, bring the detection head close to the high-tension wire that connect the distributor and the ignition coil, or to the place where all the high-tension wires of the cylinders are together.

(3). Multi-cylinder gasoline engine without distributor

Bring the detection head close to the place where the high-tension wire of each cylinder is bundled together.

The measurement is impossible if all the high-tension wires are not bundled together since the distance between the detection head and each high-tension wire differs.

2. Specifications

Applicable engine type: gasoline engine

2-cycle(1,2,3,4-cylinders)

4-cycle(1,2,3,4,5,6,8,12-cylinders)

Detection method: ignition spark noise detection

Detection object: High-tension wire or ignition cord

3. Calculating the rotational speed of engine

We could calculate the rotational speed of engine according to the measured frequency. The calculation format is as follows:

$$n = 60 * f * 1 / PR.$$

The “n” denotes the rotational speed of engine

The “f” denotes the frequency of high-tension ignition pulses.

The “PR” denotes the ratio coefficient between the “f” and “n”.

The number of “PR”, types of engines are as follows:

PR	4-cycle	2-cycle
1/2	1 cylinder	
1	2 cylinder	1 cylinder
3/2	3 cylinder	
2	4 cylinder	2 cylinder
5/2	5 cylinder	
3	6 cylinder	3 cylinder
4	8 cylinder	4 cylinder
6	12 cylinder	

**Warning: DO NOT CONTACT PROBE TIP DIRECTLY
TO THE SECONDARY IGNITION CIRCUIT.**

21. Peak Detection

The operator can pre-select the peak threshold levels, and then contact a circuit if the voltage greater than the threshold, you can hear the alarm audio. The peak threshold voltage setting loop incrementally from 0.5, to 1.0, to 2.0, to 5.0, to 48.0 and return back to 0.5 again.

Distributed by:
Electus Distribution Pty. Ltd.
320 Victoria Rd, Rydalmere
NSW 2116 Australia

www.electusdistribution.com.au

Made in China

