

Outdoor UHF/VHF TV Antenna with Rotating Motor

digitech

Instruction Manual

Model: LT3169

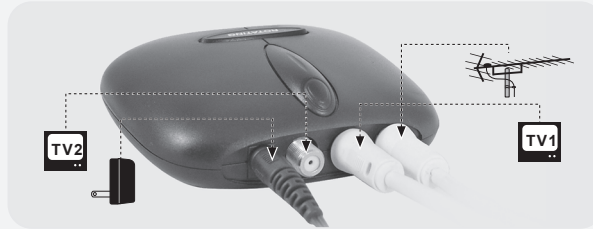
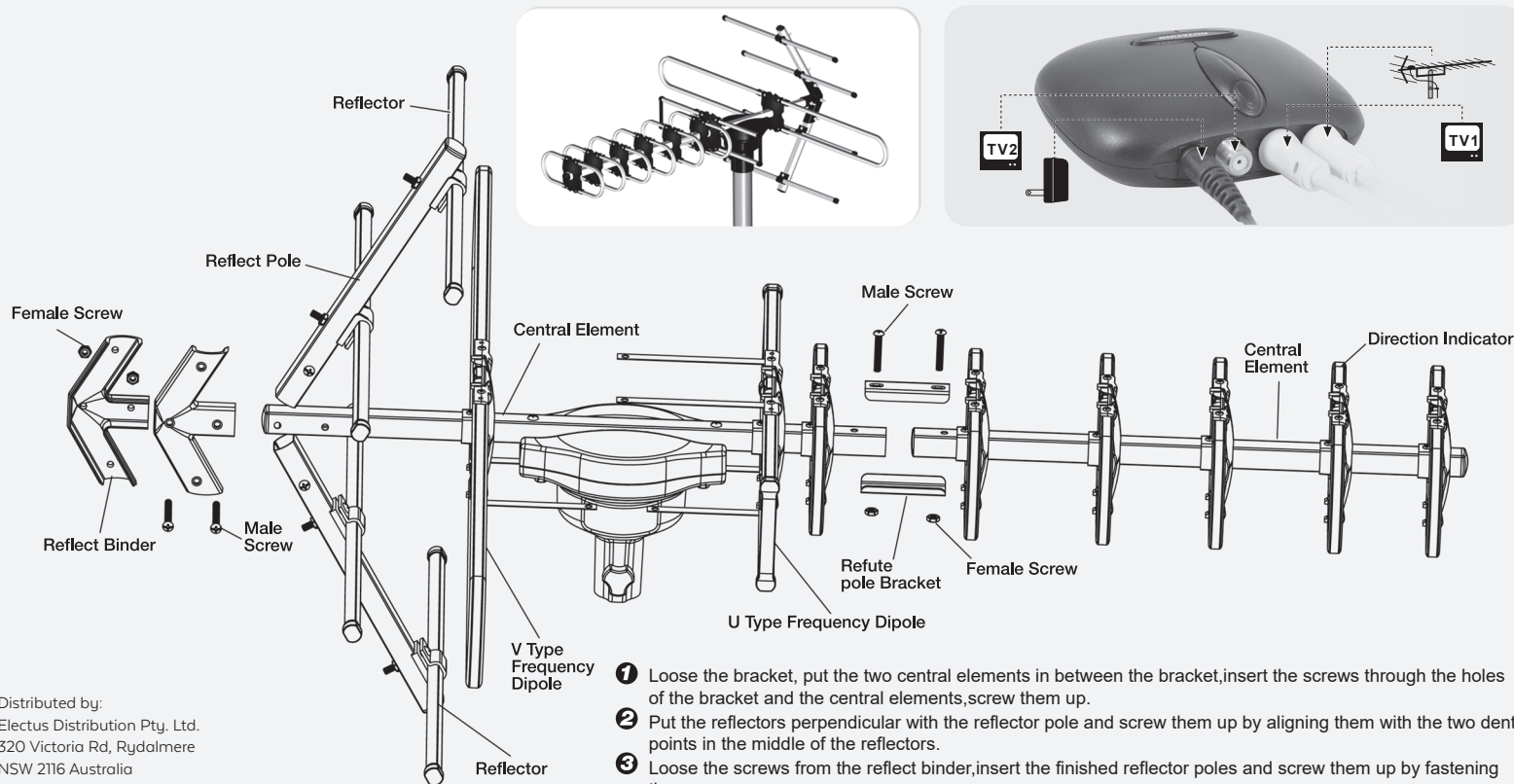

Distributed by:
Electus Distribution Pty. Ltd.
320 Victoria Rd, Rydalmere
NSW 2116 Australia

www.electusdistribution.com.au

Made in China

1. Loose the bracket, put the two central elements in between the bracket, insert the screws through the holes of the bracket and the central elements, screw them up.
2. Put the reflectors perpendicular with the reflector pole and screw them up by aligning them with the two dent points in the middle of the reflectors.
3. Loose the screws from the reflect binder, insert the finished reflector poles and screw them up by fastening the screws.
4. Unfold all the elements including the direction indicators, the U type frequency dipole and the V type frequency dipole to finish installation.