

HEXBUG®

# VEX ROBOTICS

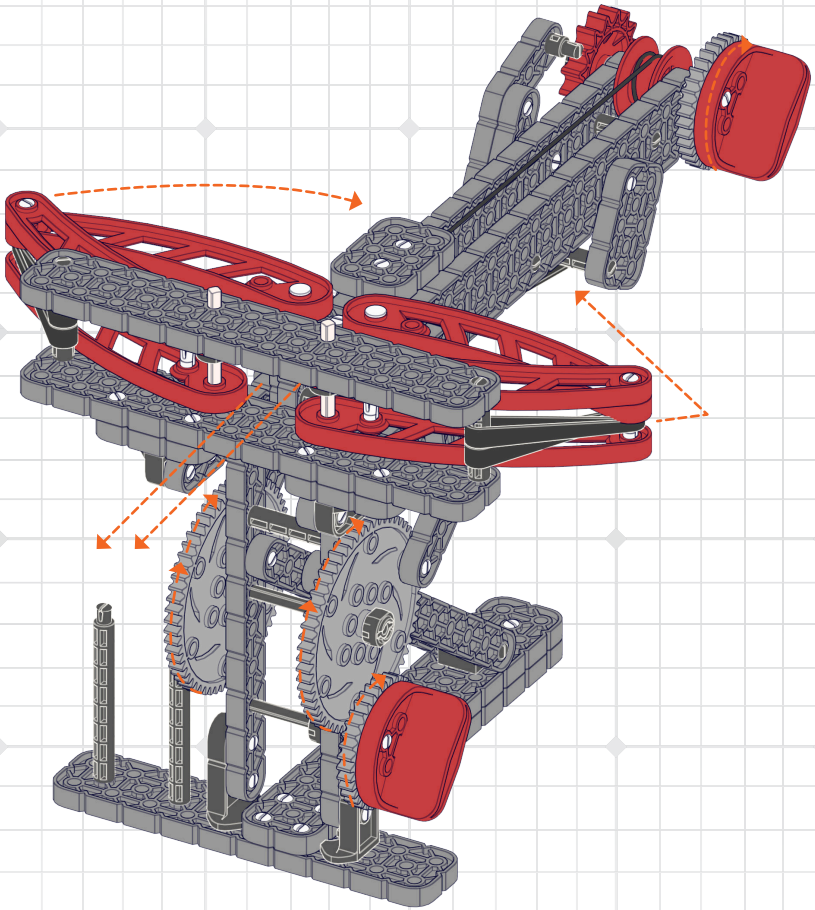

CROSSBOW™

# PARENT/ GUARDIAN • PADRE/ GUARDIÁN • ERZIEHUNGSBERECHTIGTE • GENITORE/TUTORE•

**COUNT BEFORE YOU CONNECT • CONTAR ANTES DE CONECTAR •  
COMPTER AVANT DE CONNECTER • CONTARE I PEZZI PRIMA DI  
COLLEGARLI • ERST ZÄHLEN, DANN VERBINDEN • POLICZ, ZANIM  
POŁĄCZYSZ • TELL VOORDAT U AANSLUIT**

1:1

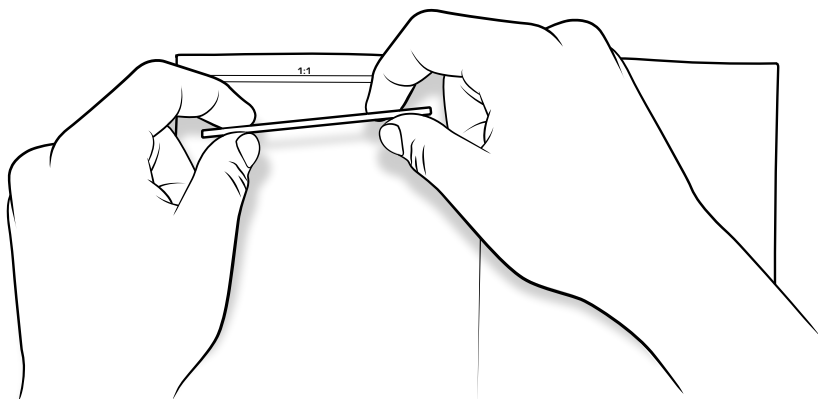
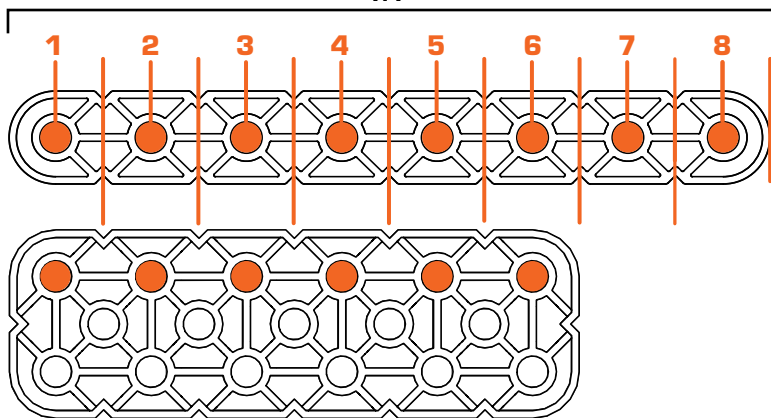

**CHECK PIECES AGAINST ACTUAL SIZE IN MANUAL  
VERIFICAR PARTES CONTRA TAMAÑO REAL EN EL MANUAL  
VERIFIEZ LES PIÈCES CONTRE LEURS TAILLES RÉELLES DANS LE MANUEL  
CONTROLLARE LE DIMENSIONI DEI PEZZI NEL MANUALE RISPETTO ALLA  
GRANDEZZA NATURALE  
BAUTEILE MIT DER ORIGINALGRÖÙE IN DER ANLEITUNG VERGLEICHEN  
SPRAWDŹ ELEMENTY WZGLĘDEM RZECZYWISTEGO ROZMIARU W INSTRUKCJI  
CHECK STUKKEN TEGEN DE WERKELIJKE GROOTTE IN DE HANDMATIC**



**ALERT  
ALERTA  
ALERTE  
ATTENZIONE  
WARNUNG  
OSTRZEŻENIE  
WAAKSCHUWING**



**CORRECT  
CORRECTO  
CORRECTE  
CORRETTO  
RICHTIG  
PRAWIDŁOWO  
CORRECT**



**FLIP  
VOLTEAR  
RETOURNER  
CAPOVOLGERE  
UMDREHEN  
PRZERZUĆ  
OMDRAAIEN**



**INCORRECT  
INCORRECTO  
INCORRECTE  
NON CORRETTO  
FALSCH  
NIEPRAWIDŁOWO  
VERKEERD**



**NOTICE  
AVISO  
AVIS  
FARE ATTENZIONE  
HINWEIS  
ZWRÓĆ UWAGĘ  
OPMERKEN**



**ALTERNATE VIEW  
VISTA ALTERNATIVA  
AUTRE VUE  
VISTA ALTERNATIVA  
ANDERE ANSICHT  
WIDOK ALTERNATYWNY  
VITZICHT**



**PARENT/TUTEUR • ELTERN /  
OUDER/ VOOGD • RODZIC / OPIEKUN**

**REMOVE CONNECTORS  
RETIRAR CONECTORES  
RETIRES CONNECTEURS  
RIMUOVERE I CONNETTORI  
VERBINDUNGSSTÜCKE ENTFERNEN  
WYJMIJ ŁĄCZNIKI  
VERWIJDER CONNECTORS**

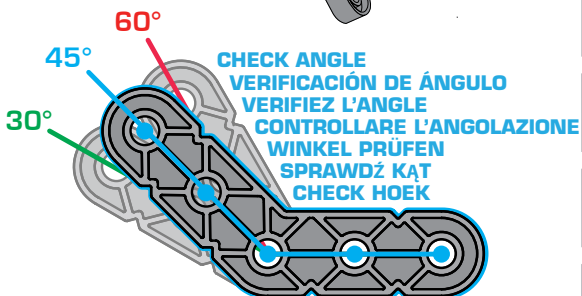
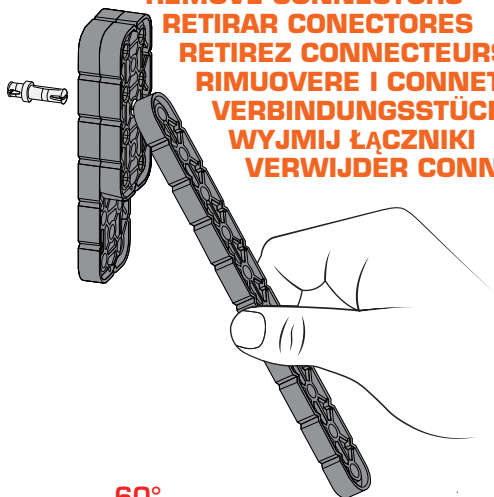

**CHECK ANGLE  
VERIFICACIÓN DE ÁNGULO  
VERIFIEZ L'ANGLE  
CONTROLLARE L'ANGOLAZIONE  
WINKEL PRÜFEN  
SPRAWDŹ KĄT  
CHECK HOEK**

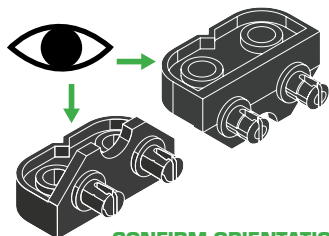

**CONFIRM ORIENTATION  
CONFIRMAR ORIENTACIÓN  
CONFIRMEZ L'ORIENTATION  
CONFERMARE L'ORIENTAMENTO  
AUSRICHTUNG PRÜFEN  
POTWIERDŹ ORIENTACJĘ  
BEVESTIG ORIENTATIE**



**ROTATE  
GIRAR  
FAIRE TOURNER  
RUOTARE  
DREHEN  
OBRÓĆ  
DRAAIEN**



**WIND UP  
DAR CUERDA  
LIQUIDER  
ARROTOLA  
AUFZIEHEN  
NAWIN  
OPWINDEN**

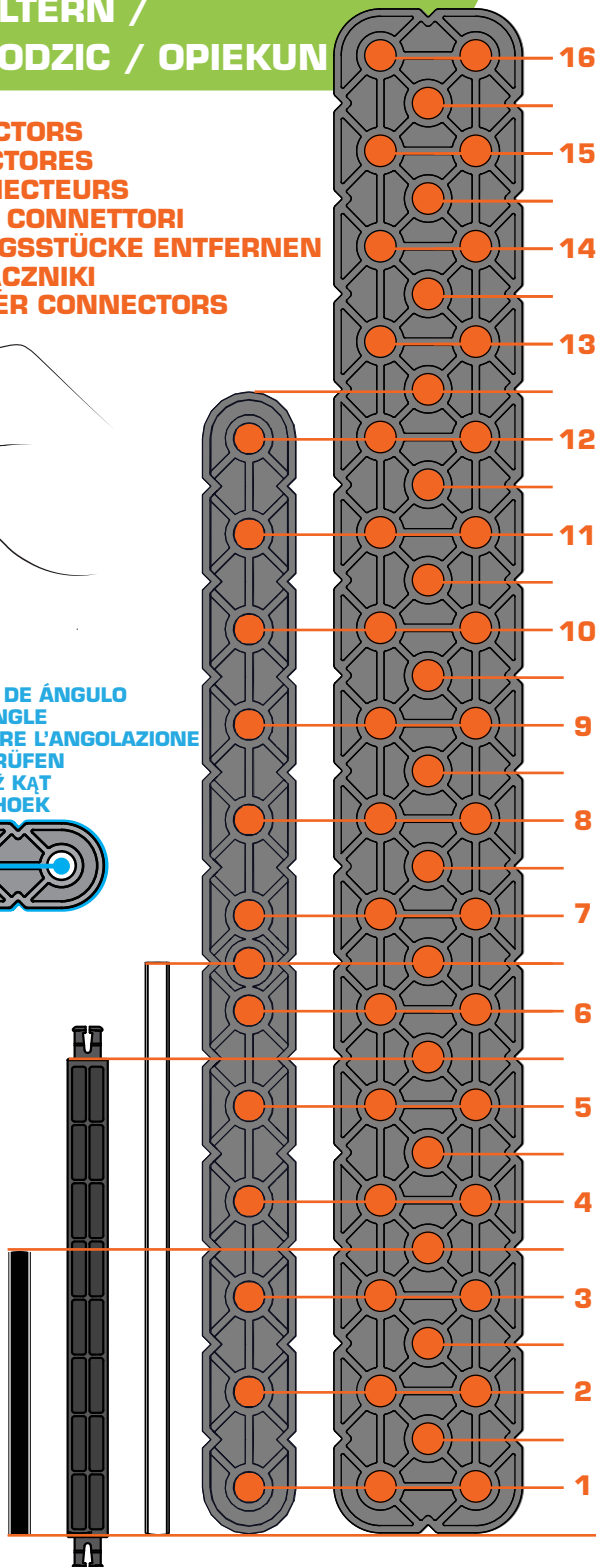

# PARTS / PARTES / LES PIÈCES / BAUTEILE / PARTI /



**1x**

228-3201-063

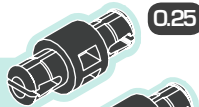

**4x**

228-3201-065

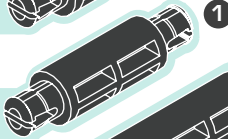

**4x**

228-3201-067

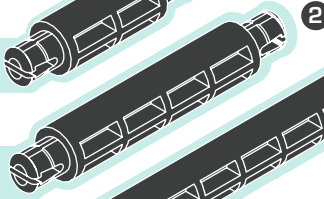

**2x**

228-3201-070

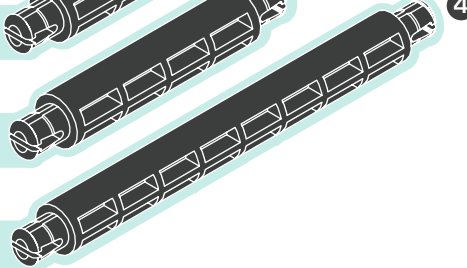

**44x**

228-3943-060



**5x**

228-3943-061

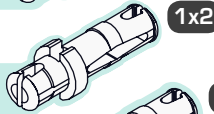

**4x**

228-3943-062

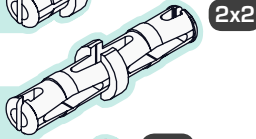

**2x**

228-3943-086

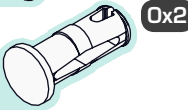

**2x**

228-3201-131



**2x**

228-3201-128

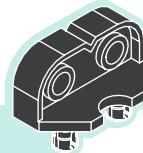

**1x**

228-3201-270

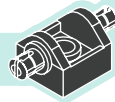

**6x**

228-4143-293

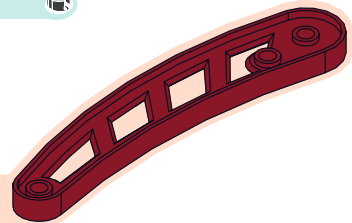

**1x**

228-3611-148

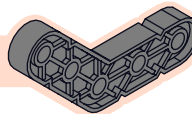

3x3 45°

3x3 60°

**2x**

228-3611-149

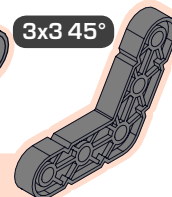

# CZESCI/ ONDERDELEN



- 2x** 228-3611-004 **1x5**
- 2x** 228-3611-007 **1x8**
- 2x** 228-3611-009 **1x10**
- 2x** 228-3611-010 **1x11**
- 6x** 228-3611-018 **2x3**
- 2x** 228-3611-019 **2x4**
- 1x** 228-3611-023 **2x8**
- 1x** 228-3611-025 **2x10**
- 3x** 228-3611-026 **2x12**
- 2x** 228-3611-028 **2x16**

# PARTS / PARTES / LES PIÈCES / BAUTEILE / PARTI /

**6x**

228-2500-143



64

**3x**

228-3201-114



5

**3x**

499-2850-056

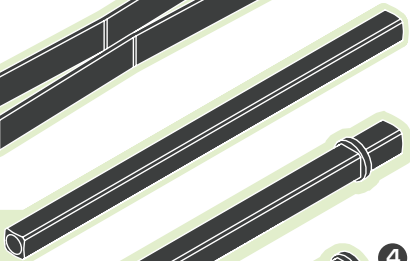

4

**1x**

228-3201-077

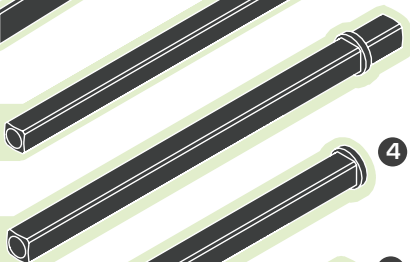

4

**1x**

228-3201-079

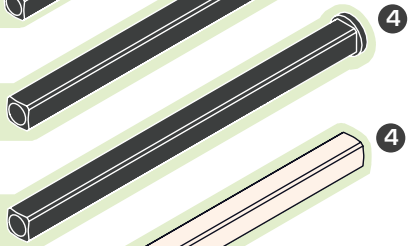

4

**1x**

228-3201-082

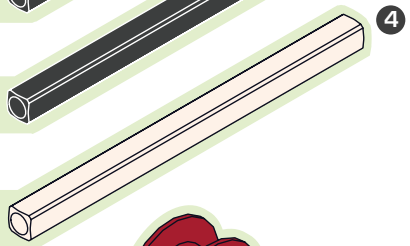

**2x**

228-2500-120



**1x**

228-4133-420



16t

**1x**

228-4133-233

**2x**

228-4143-354

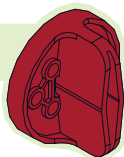



**1x** 228-3616-213

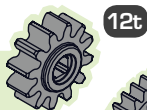

**2x** 228-3616-214

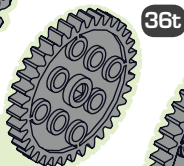

**2x** 228-3616-215

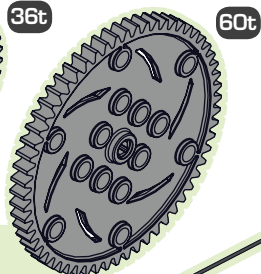

**1x** 228-2500-436

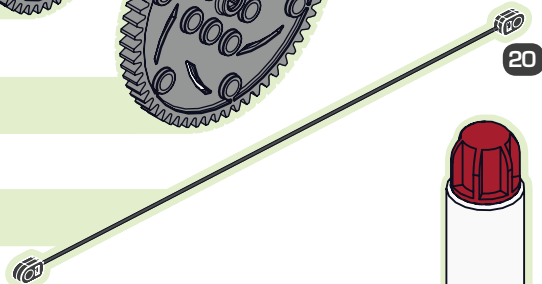

**3x** 228-2500-506



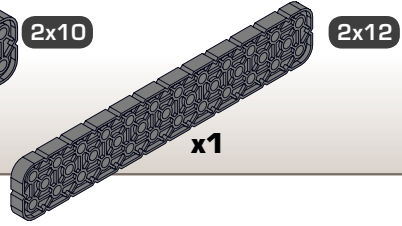
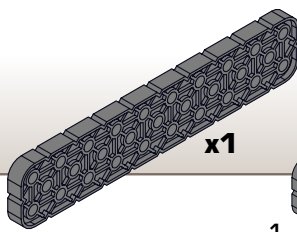
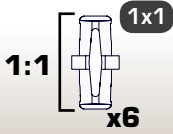

1

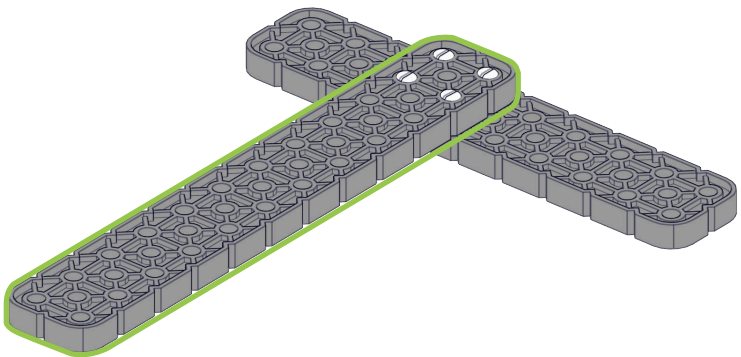
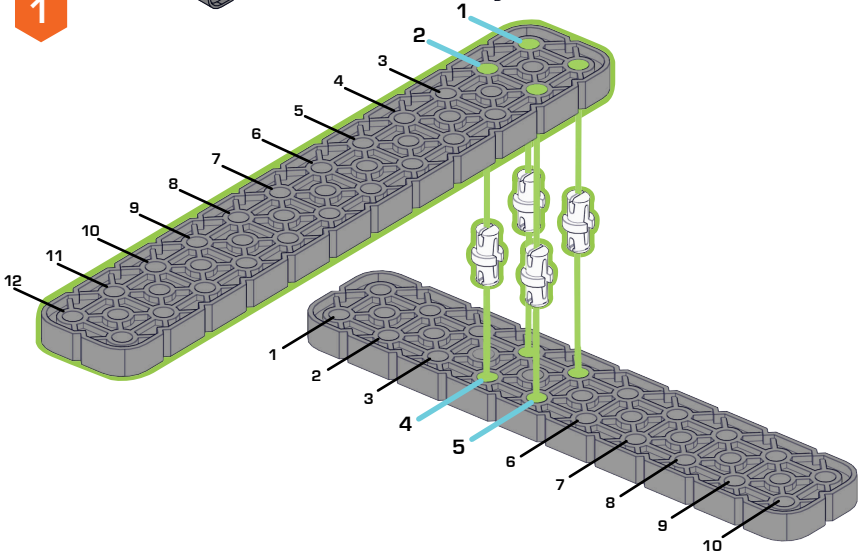

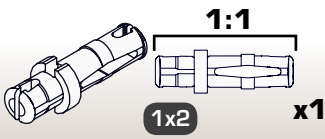

1x2

2x8

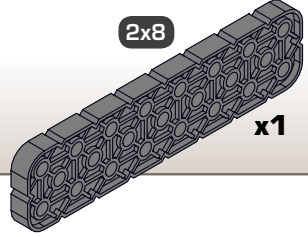

2

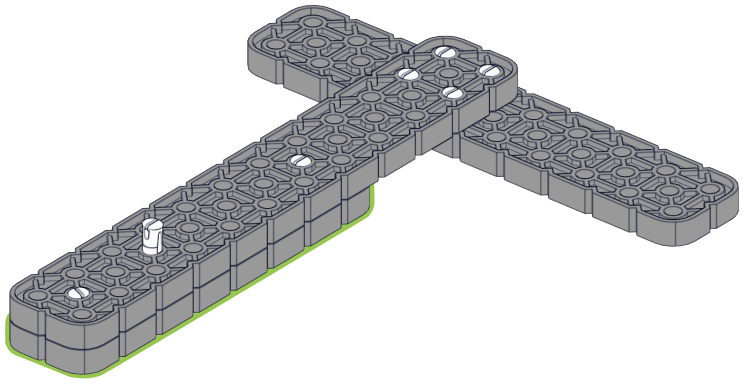
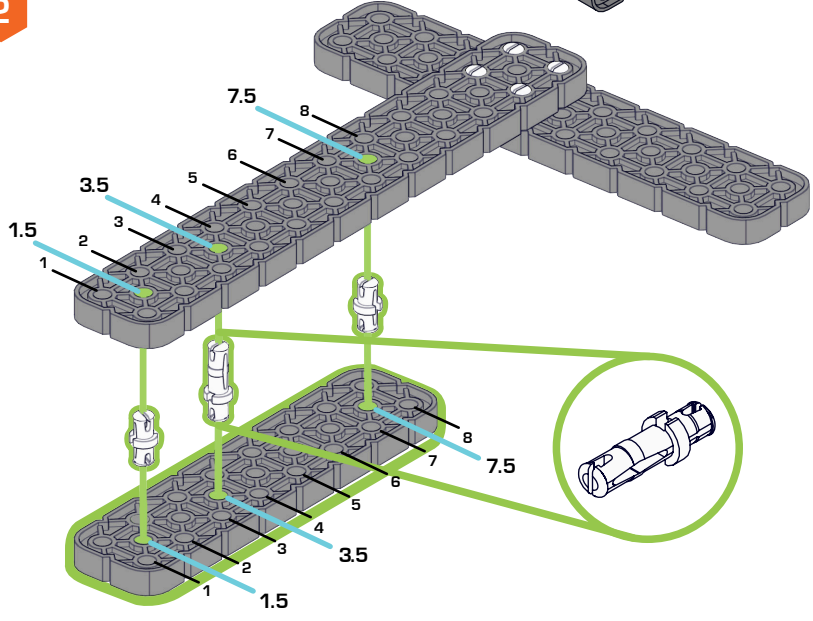



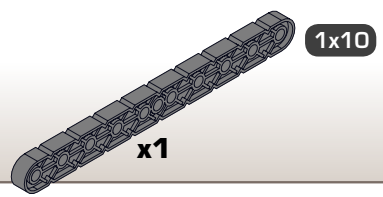
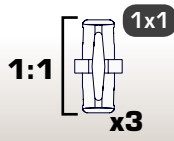

3

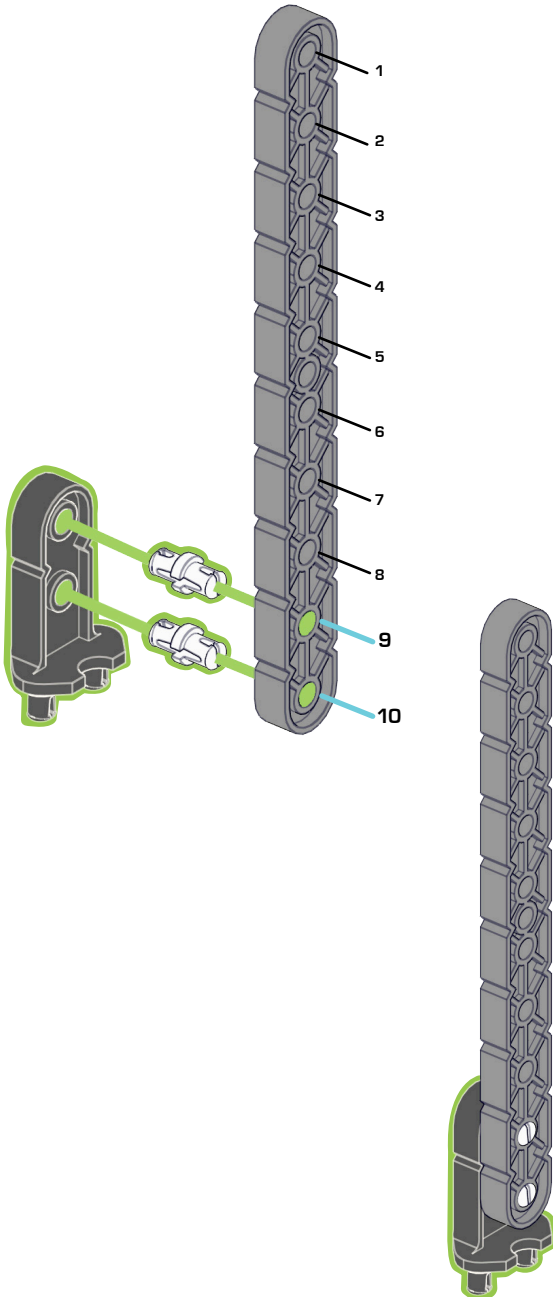

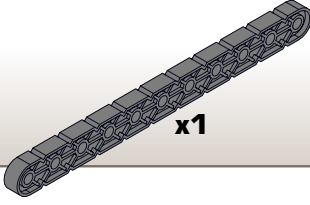

1x11

x1

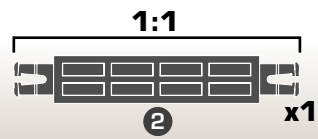

4

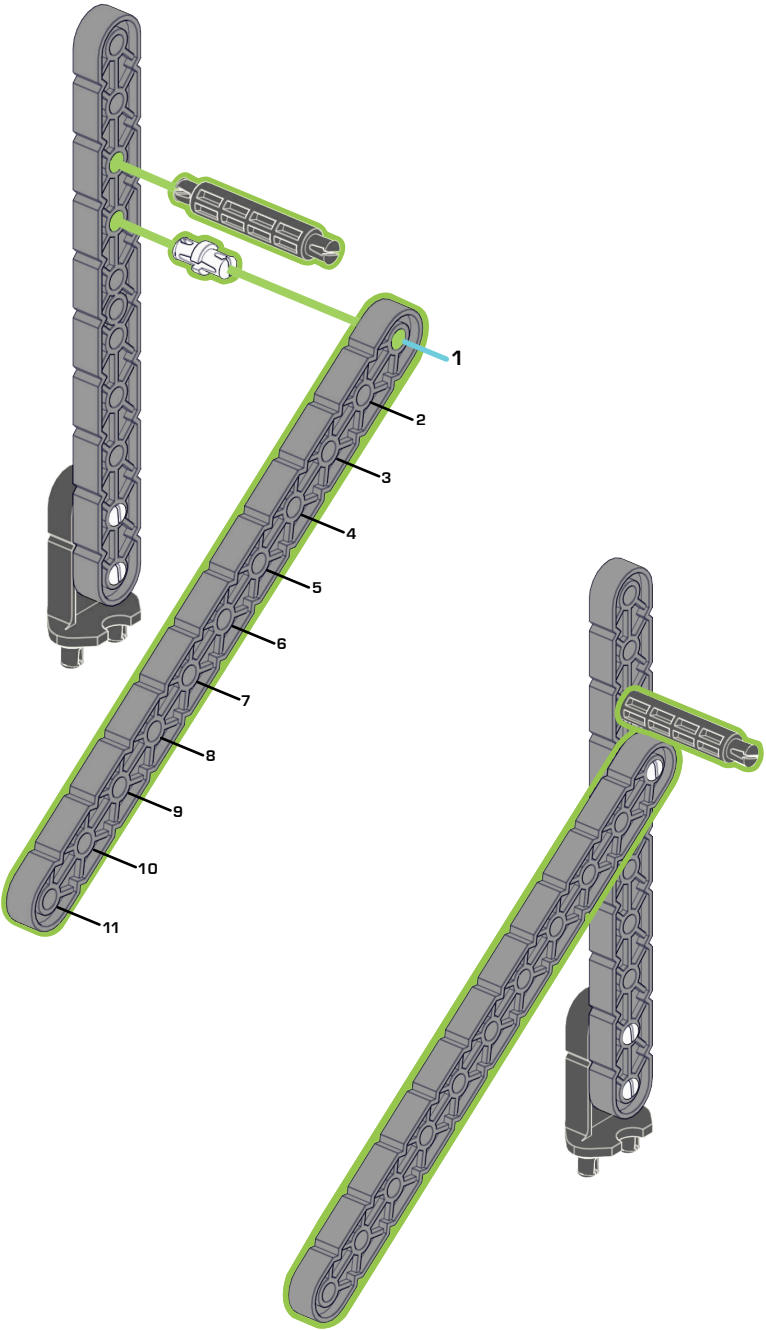



x1

1:1



x1

1x1

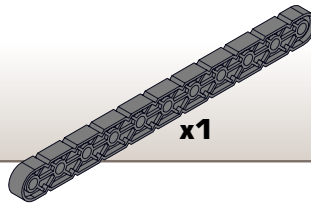

x1

1x11

5

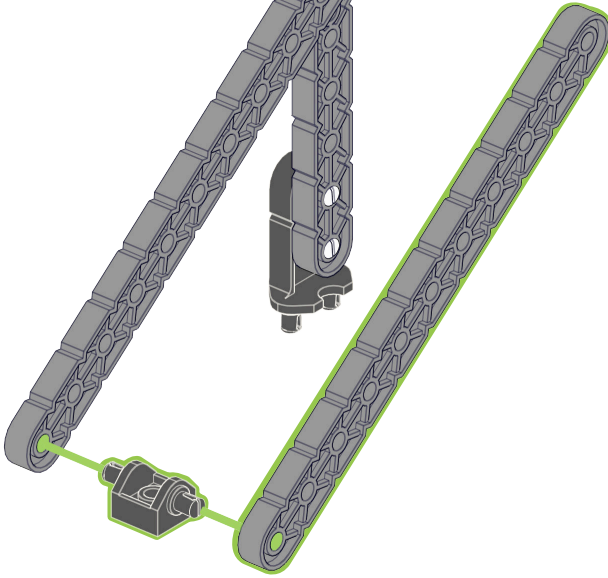
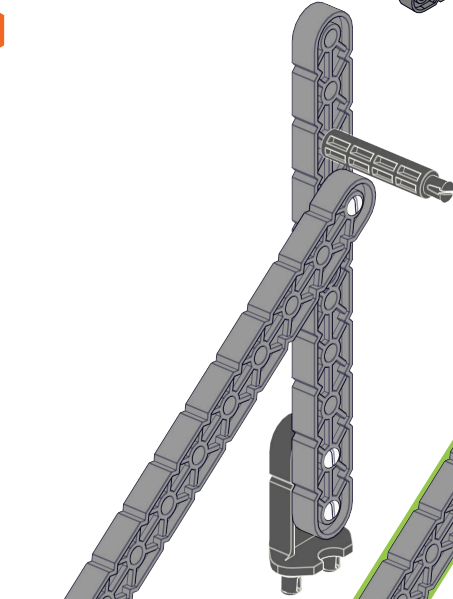

1x11

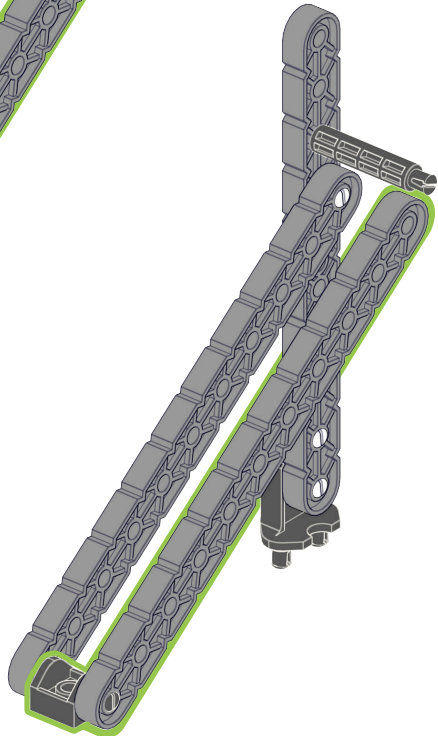

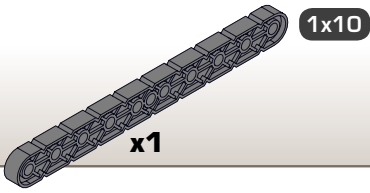

6

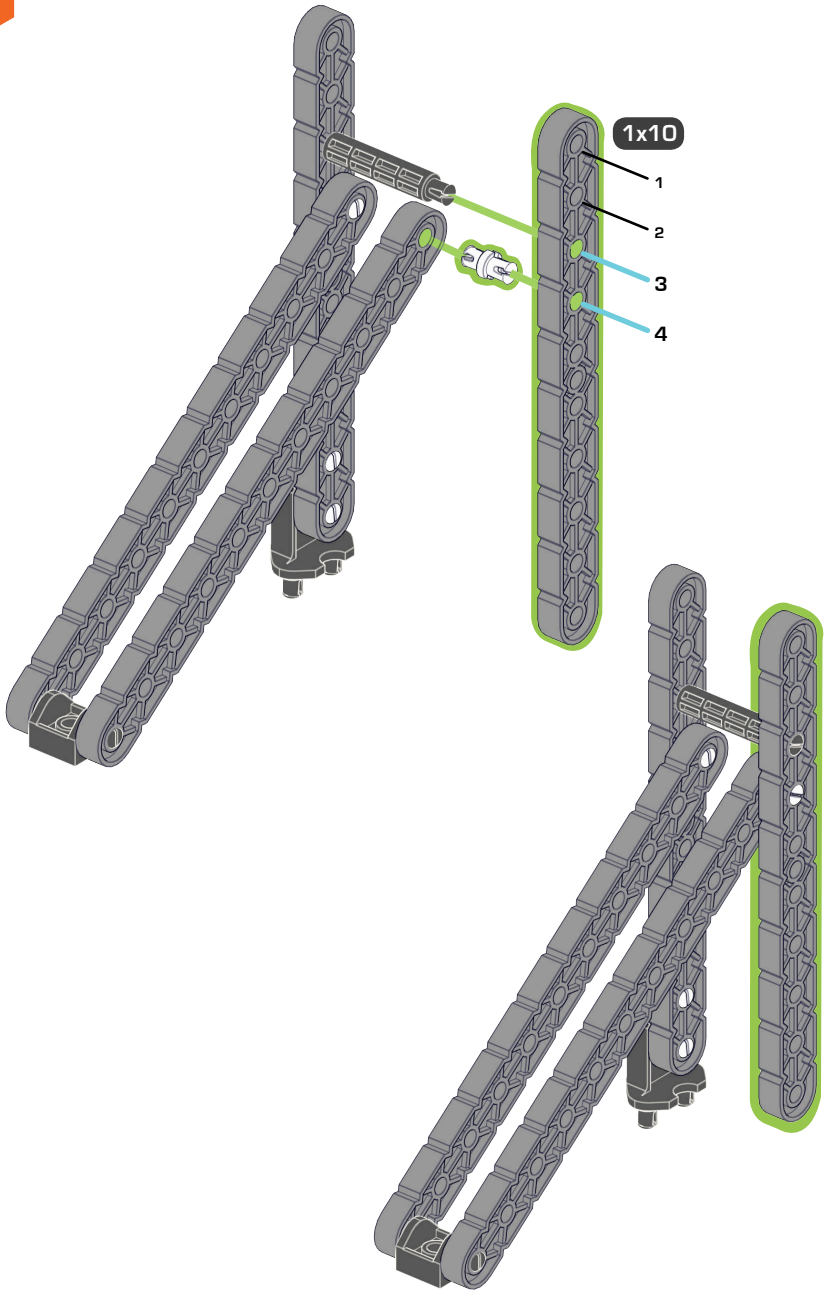



1:1

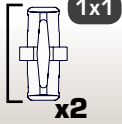

1x1

x1

x2

7

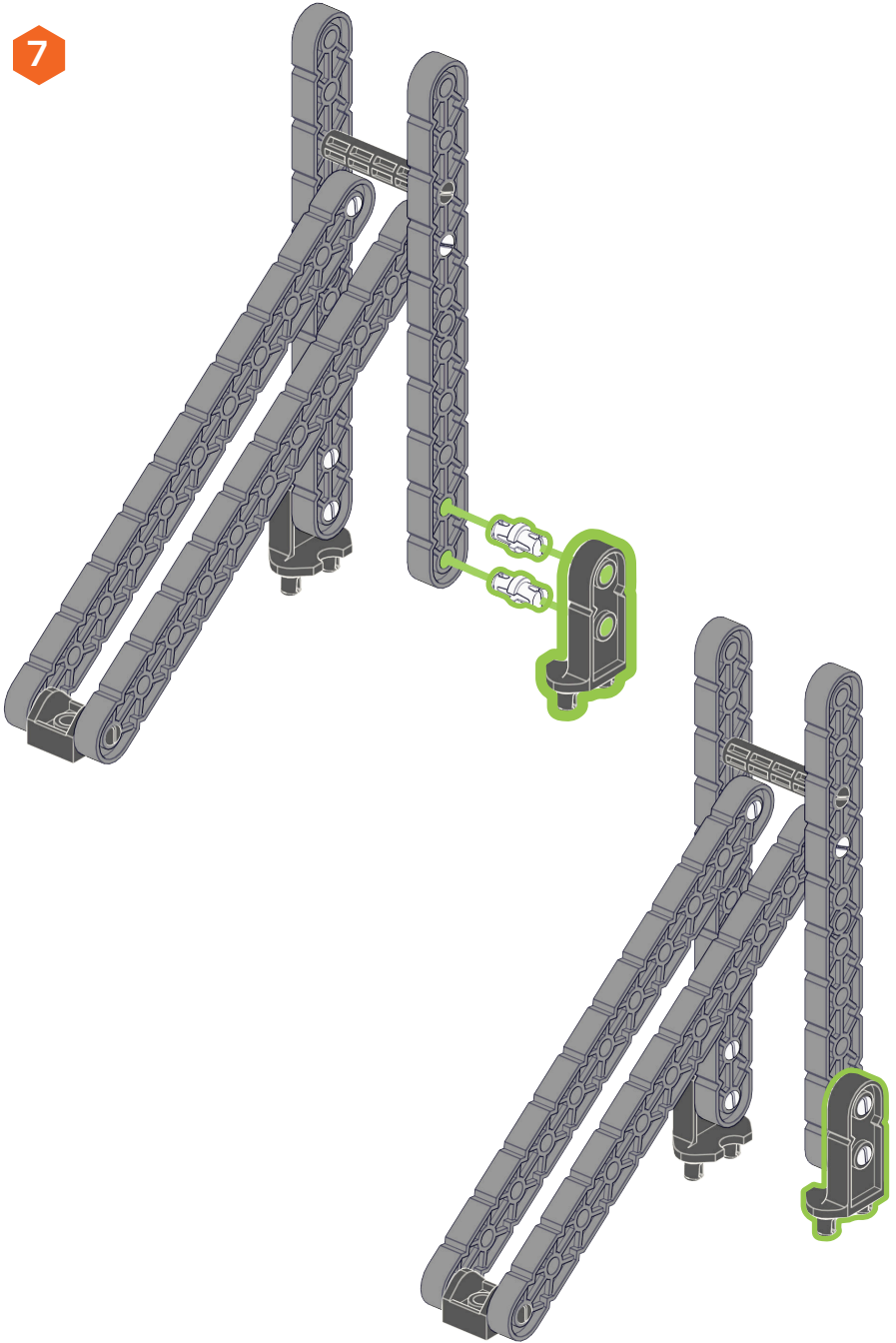

8

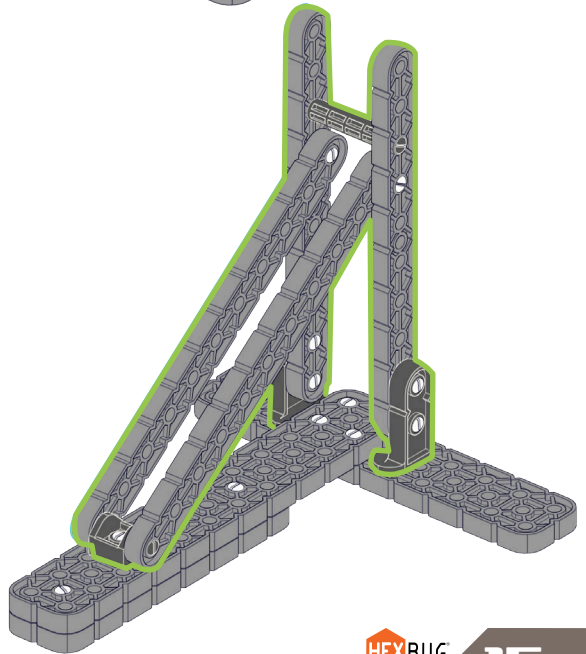
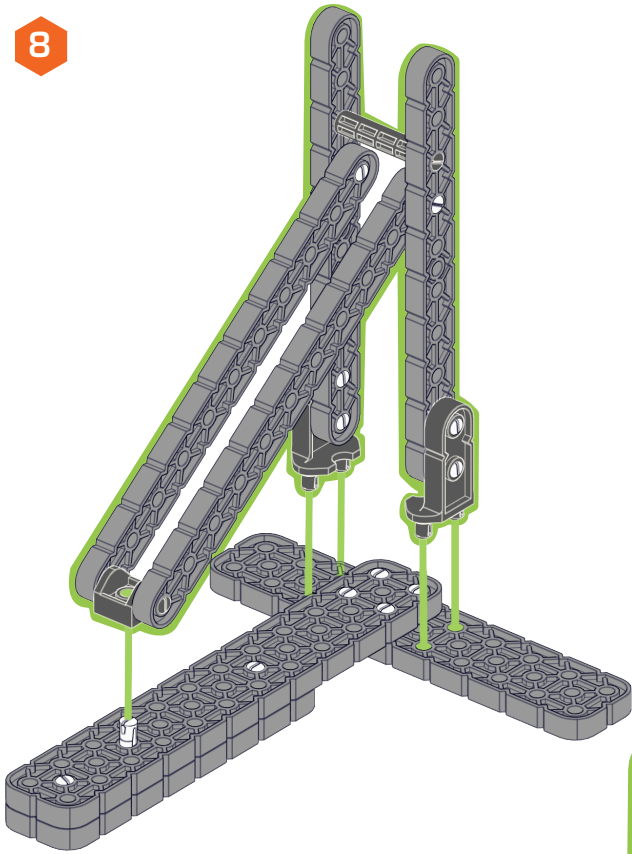

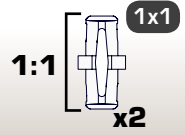

9

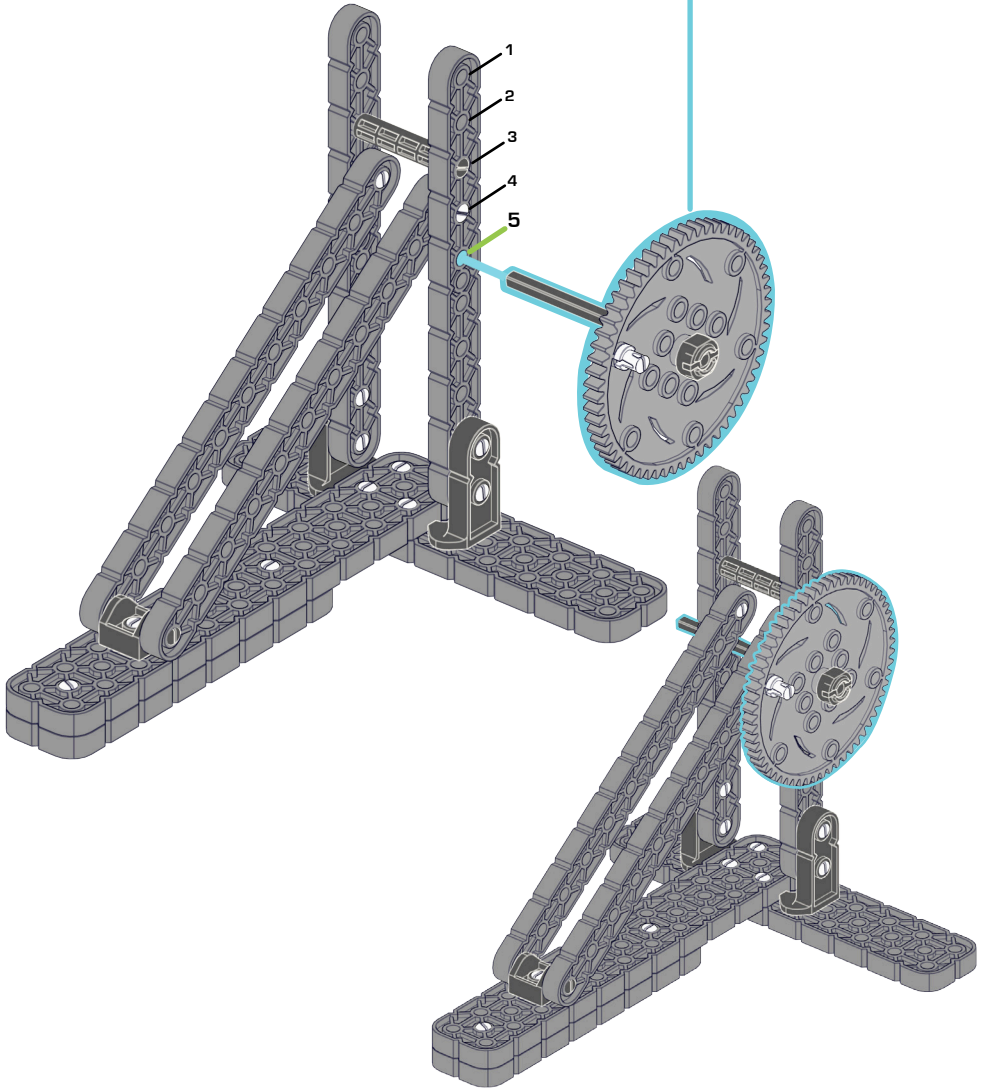
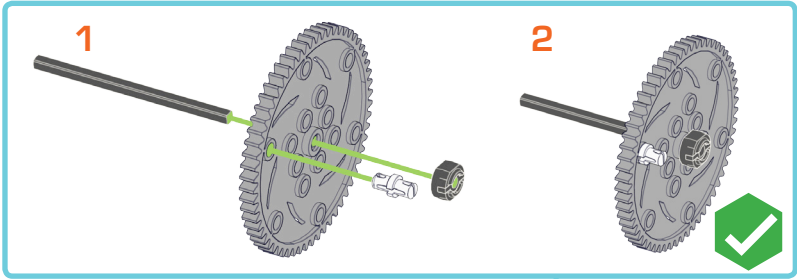



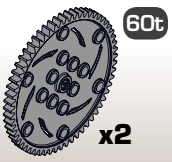

10

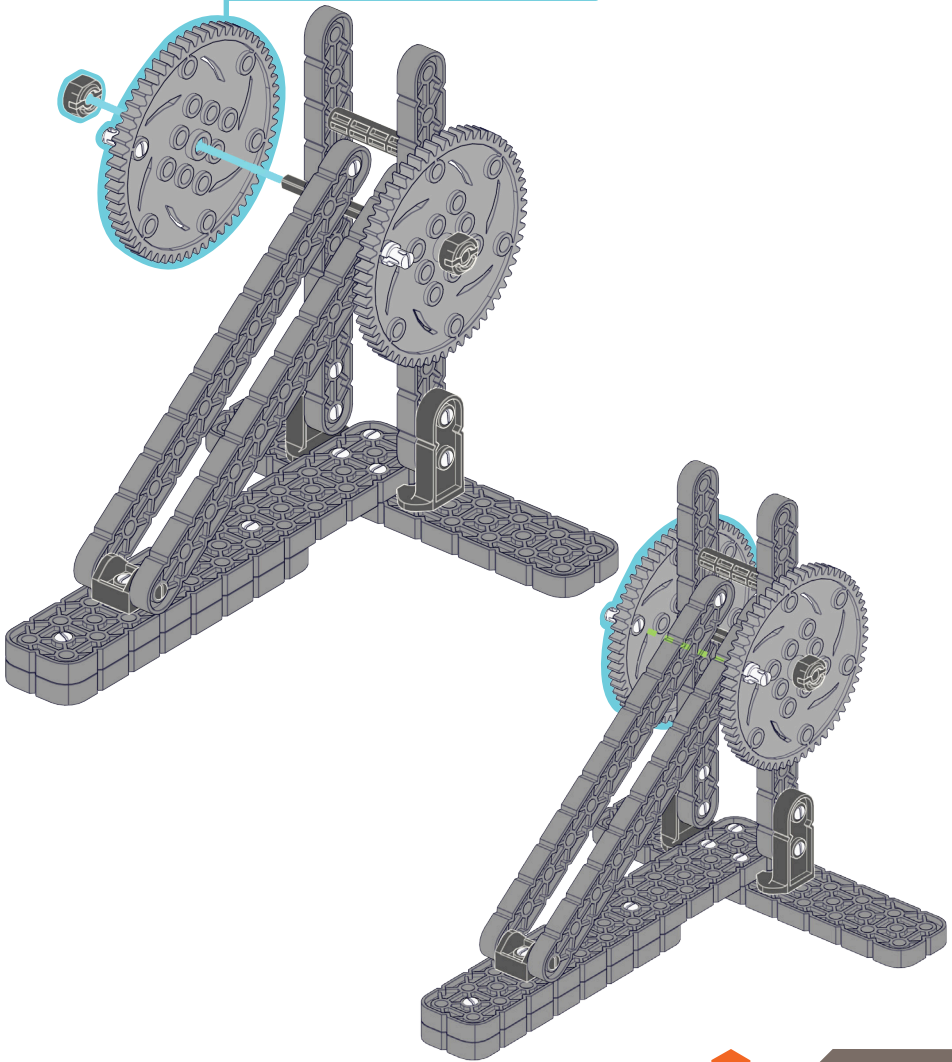
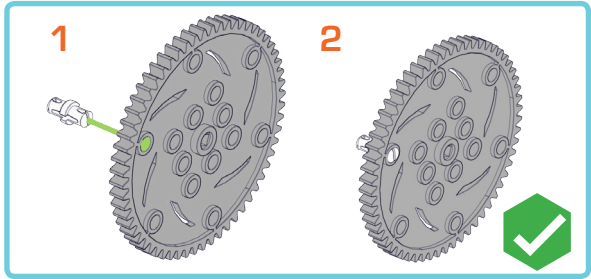

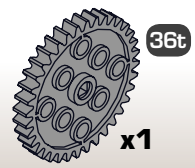
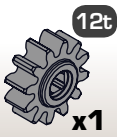

11

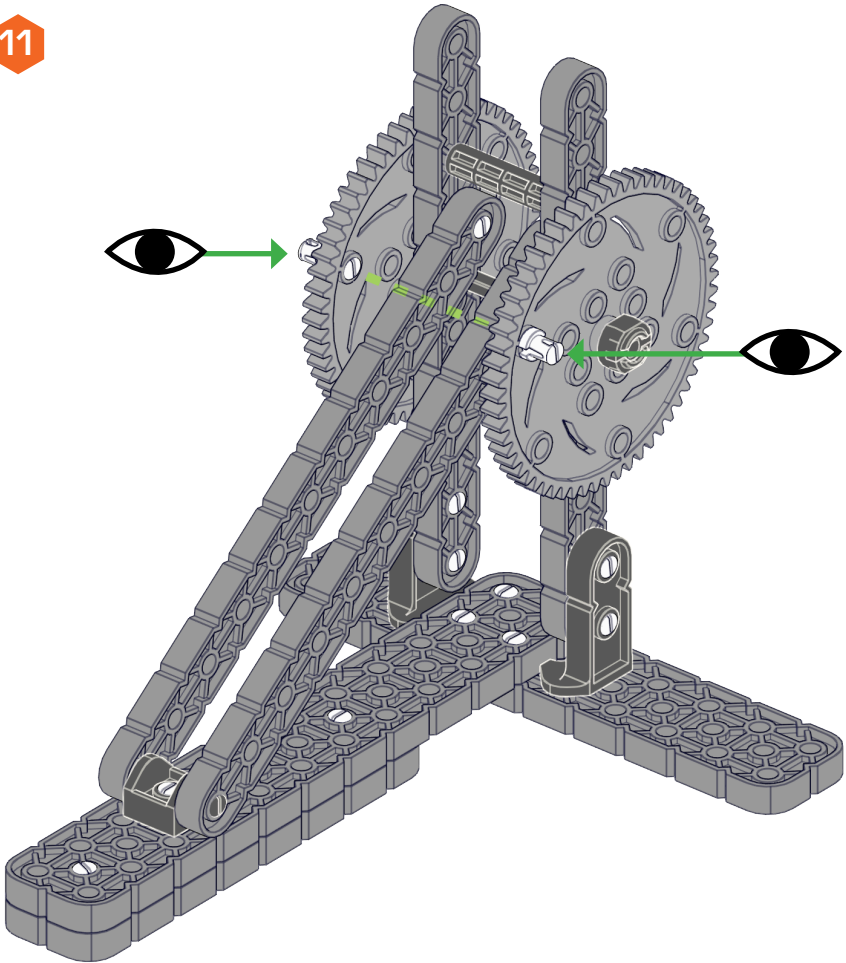

12

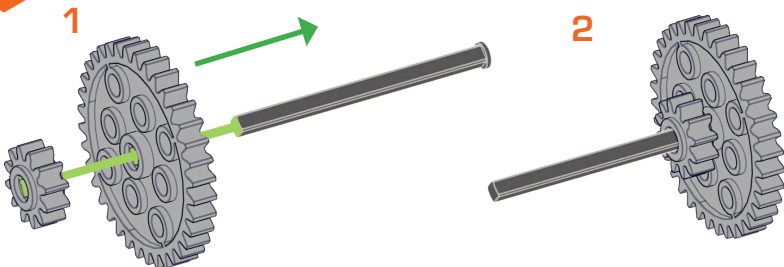



13

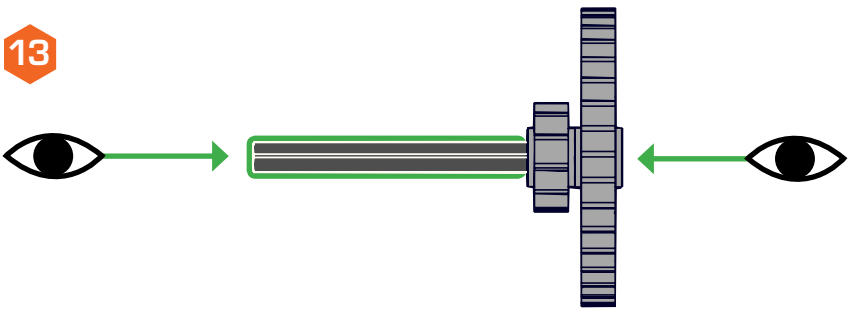

14

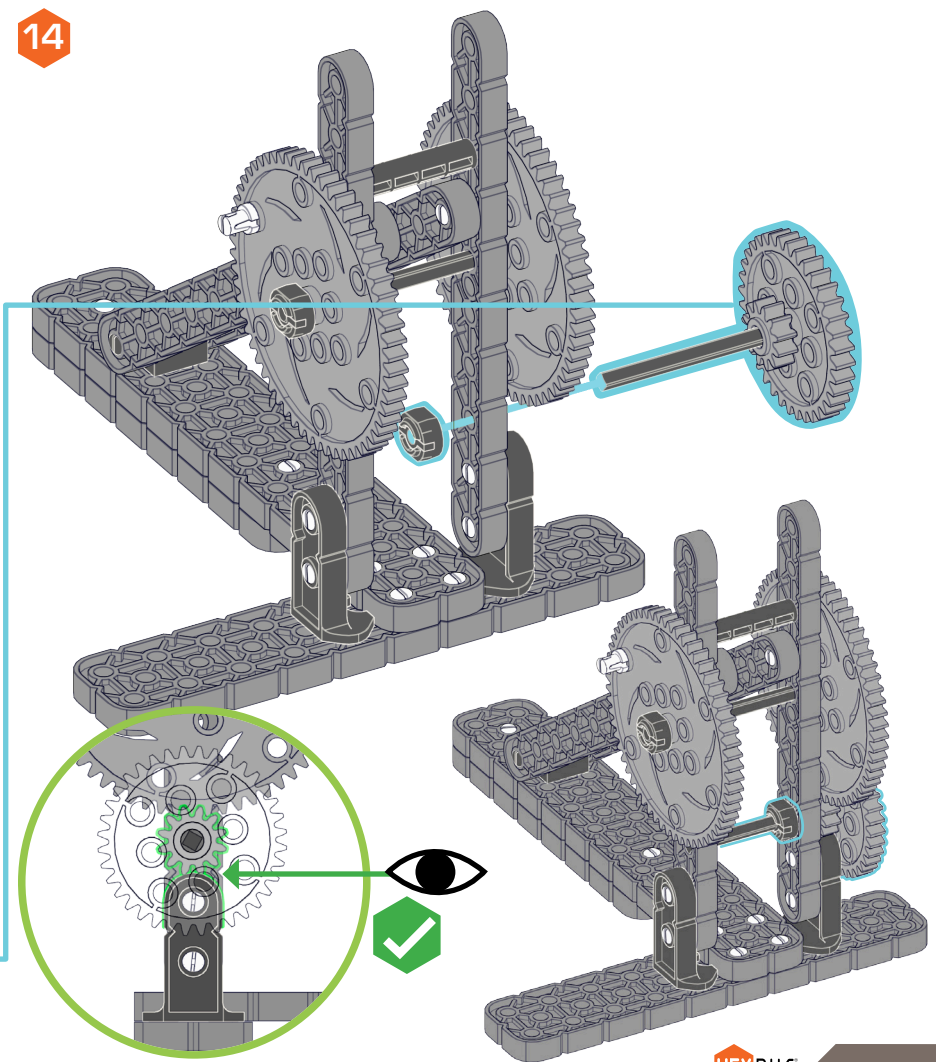

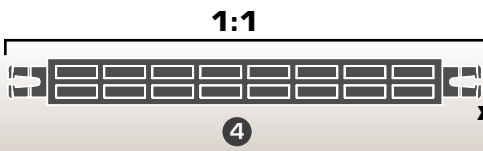

x2

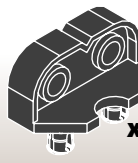

x1

1x8

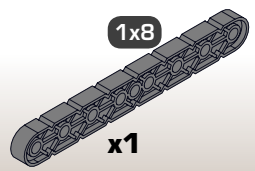

x1

15

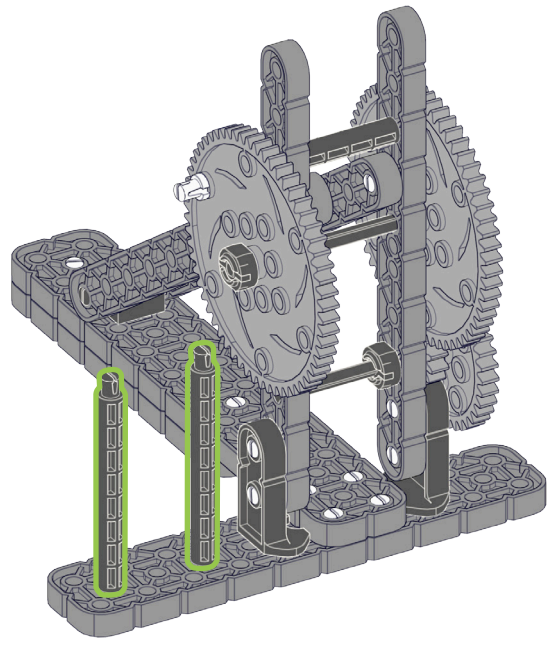
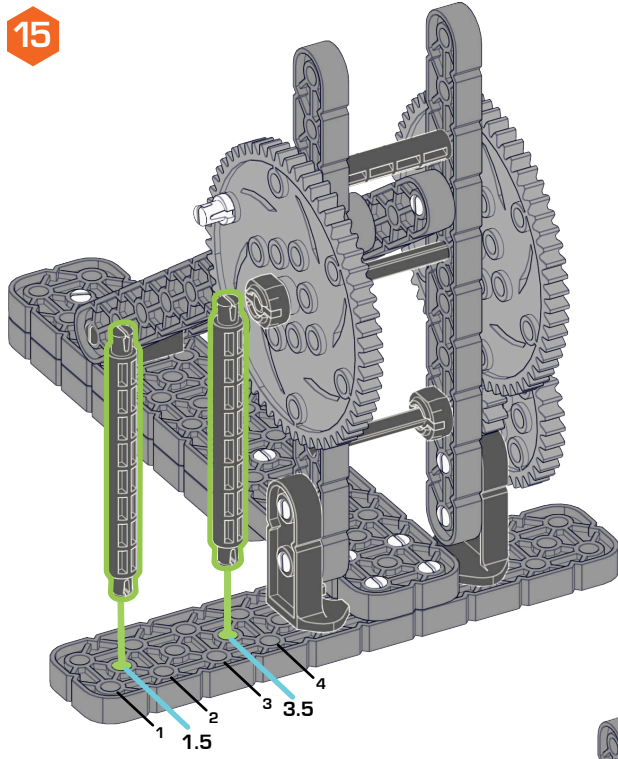

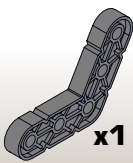

3x3 60°

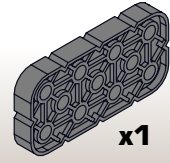
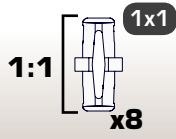

2x4

16

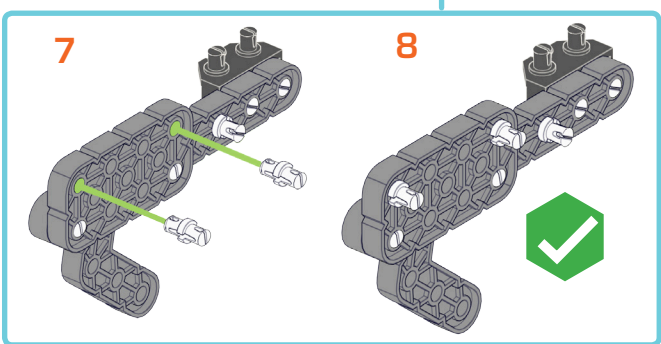
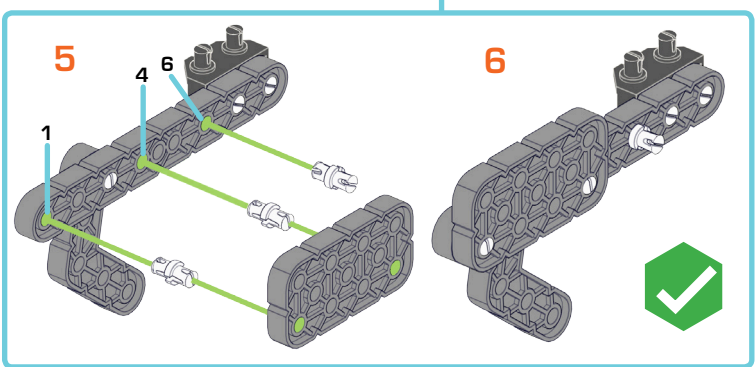
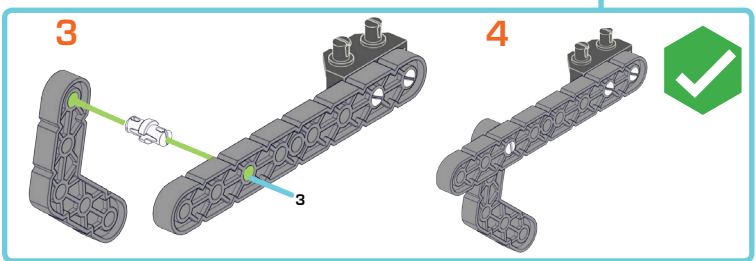
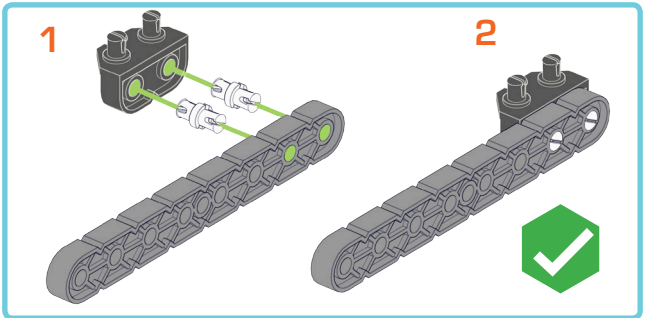



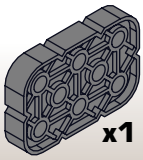

2x3

x1



1x1

1:1

x1

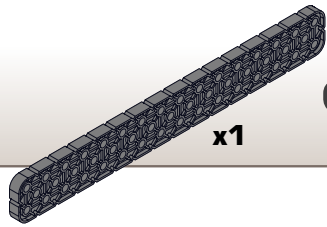

2x16

x1

17

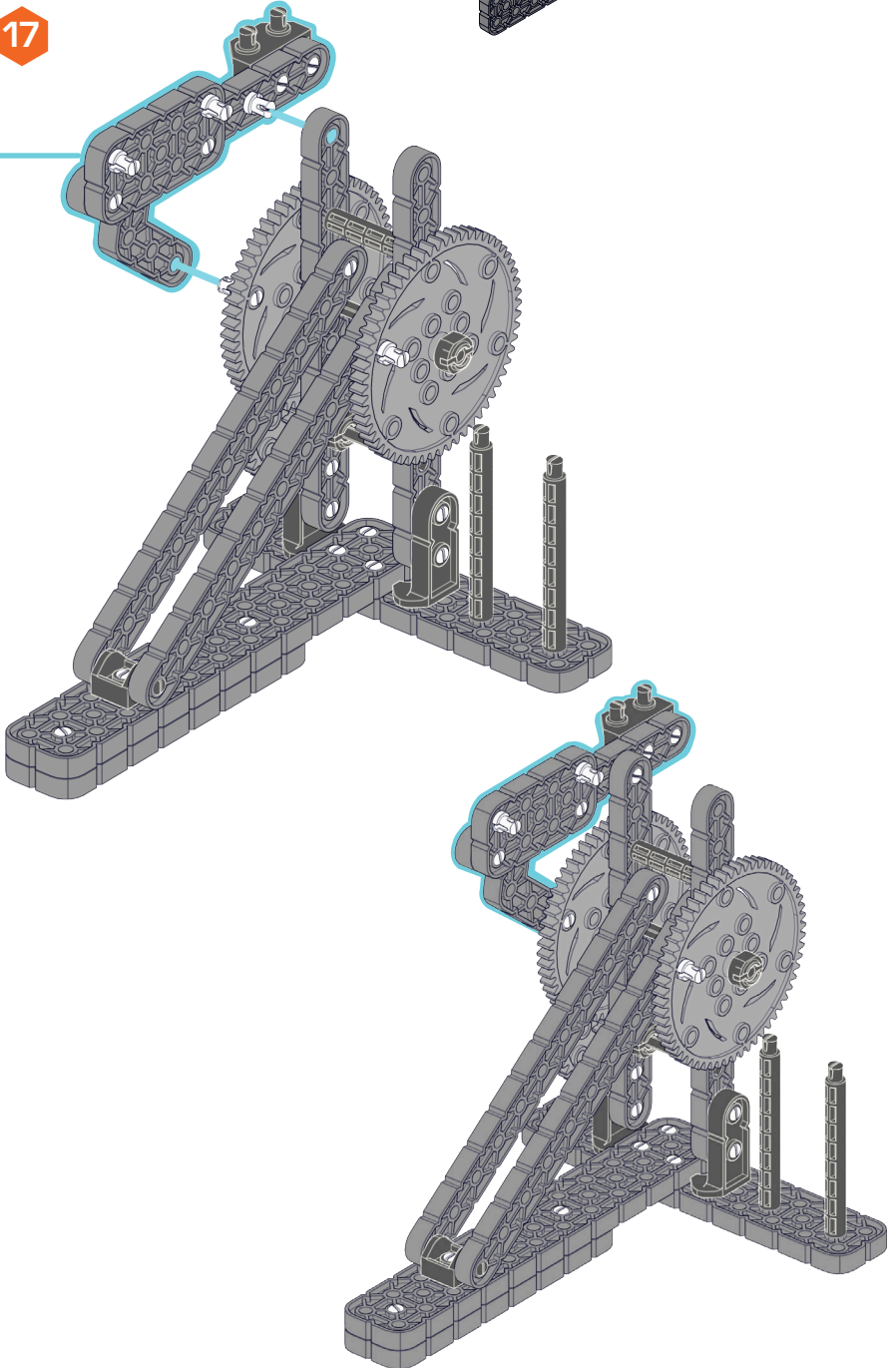

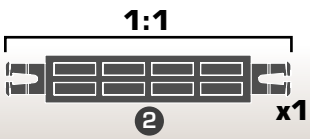

18

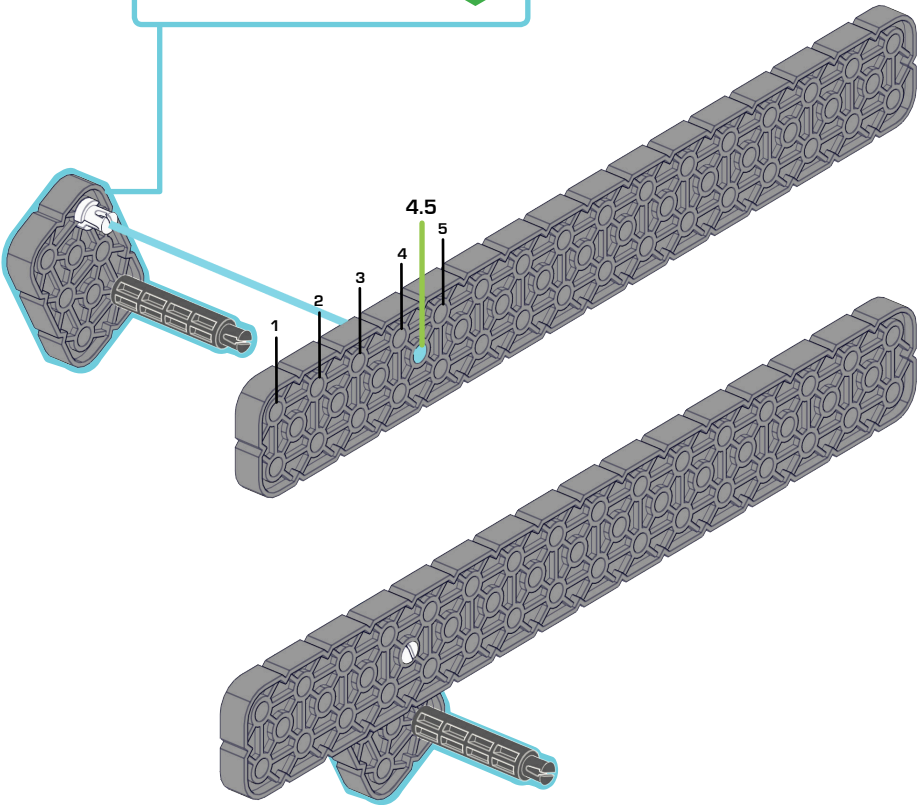
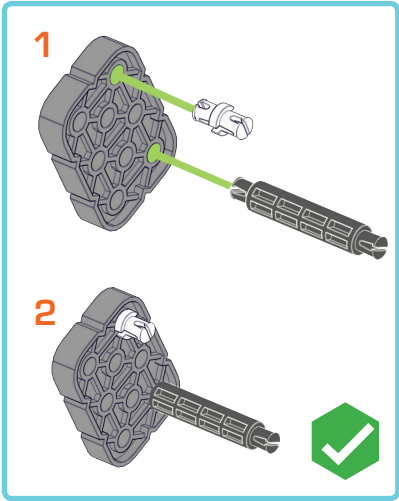



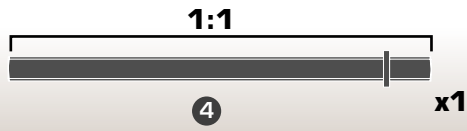
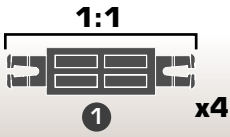

19

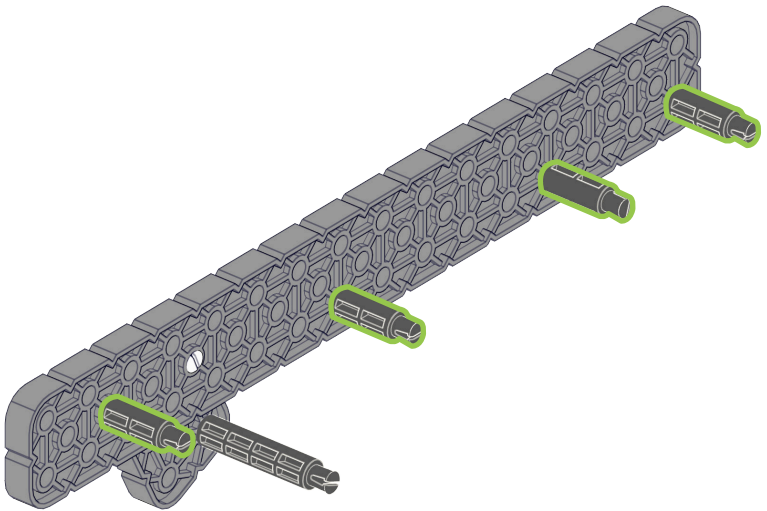
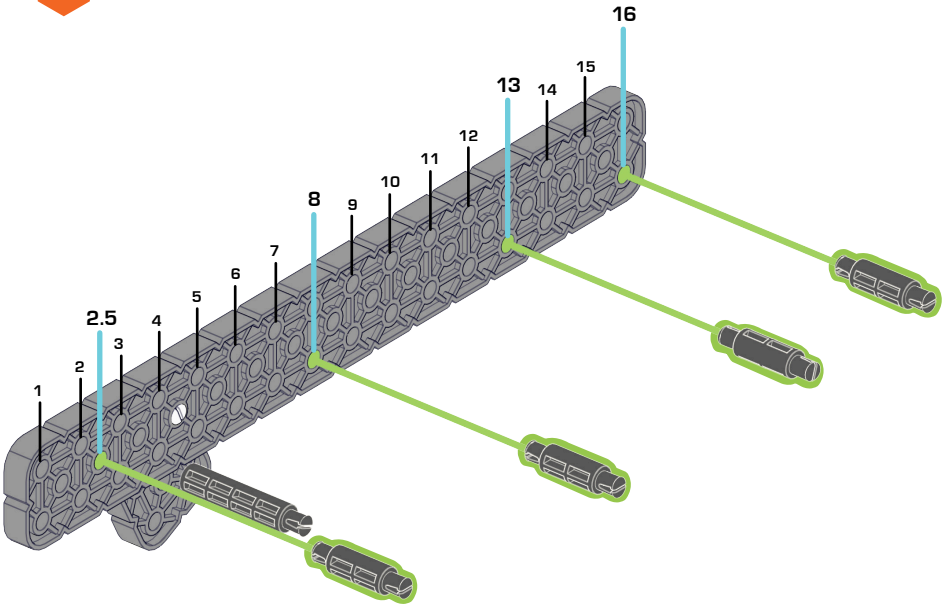

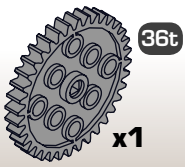

20

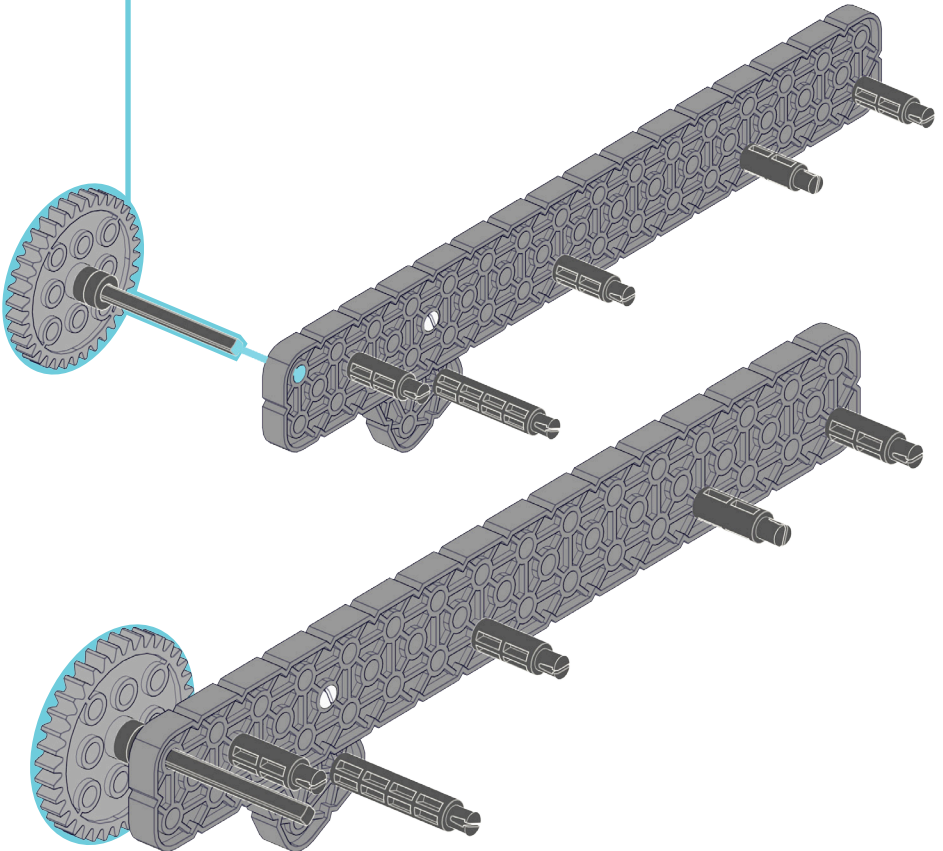
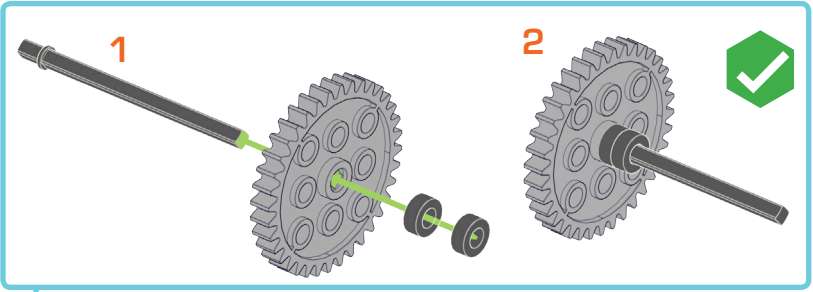

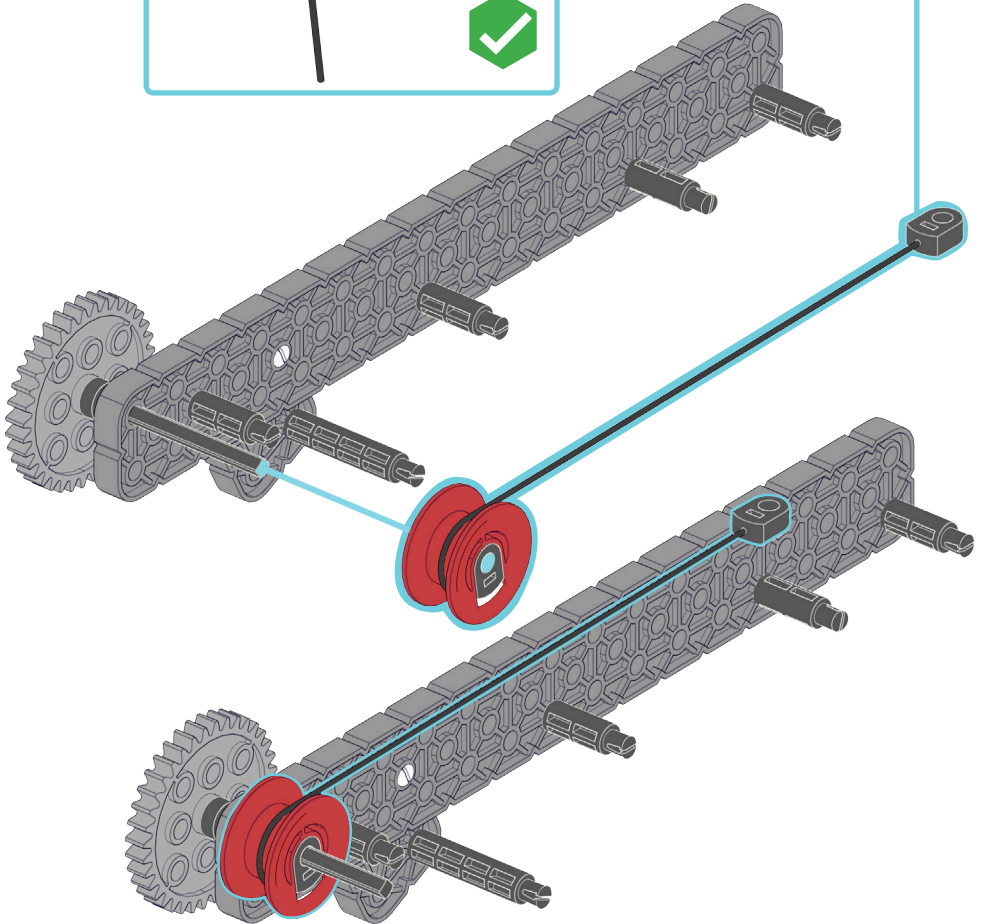
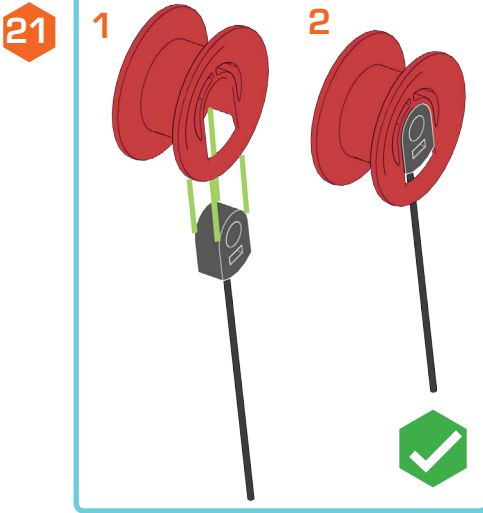
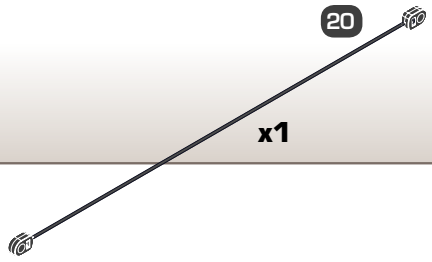
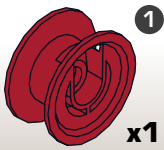

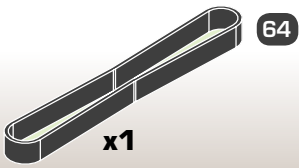

22

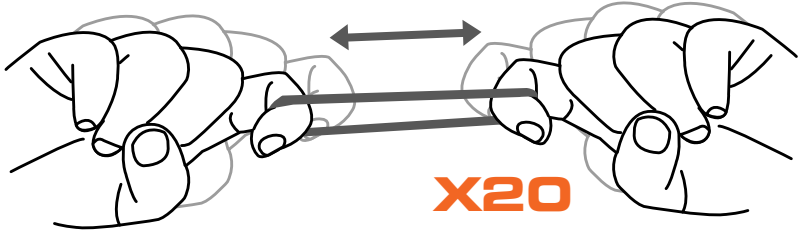

23

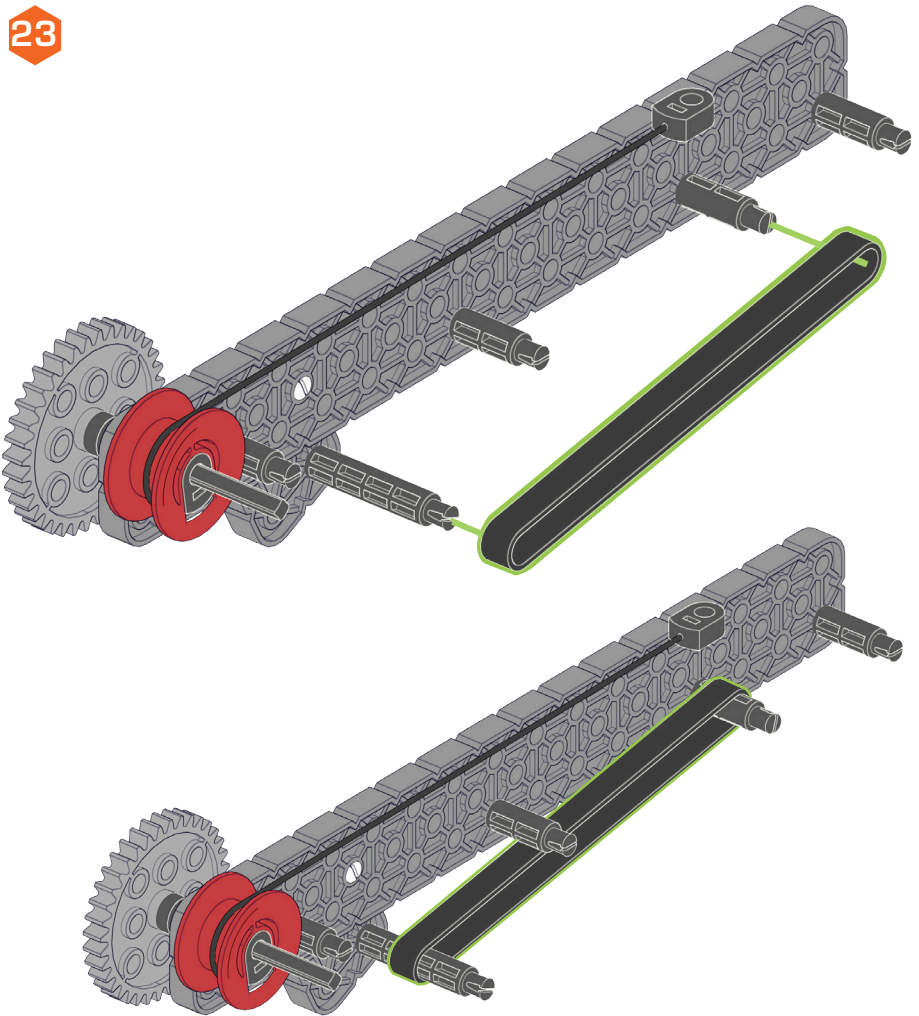

24

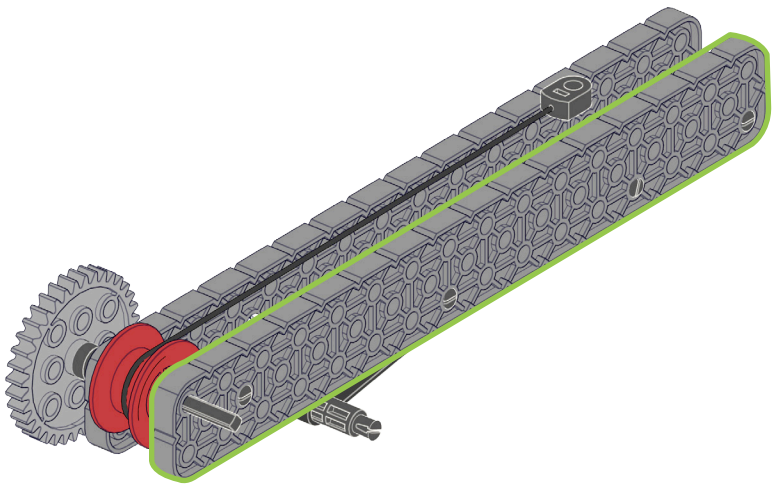
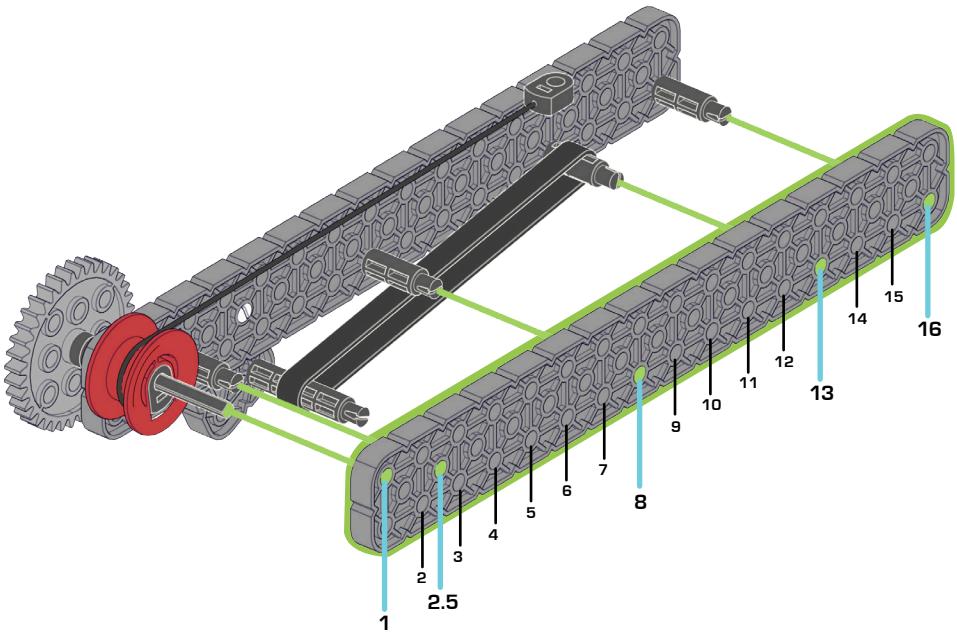
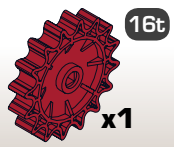
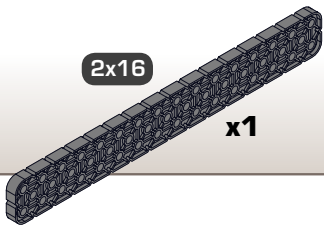



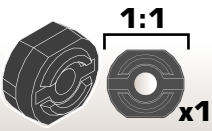

25

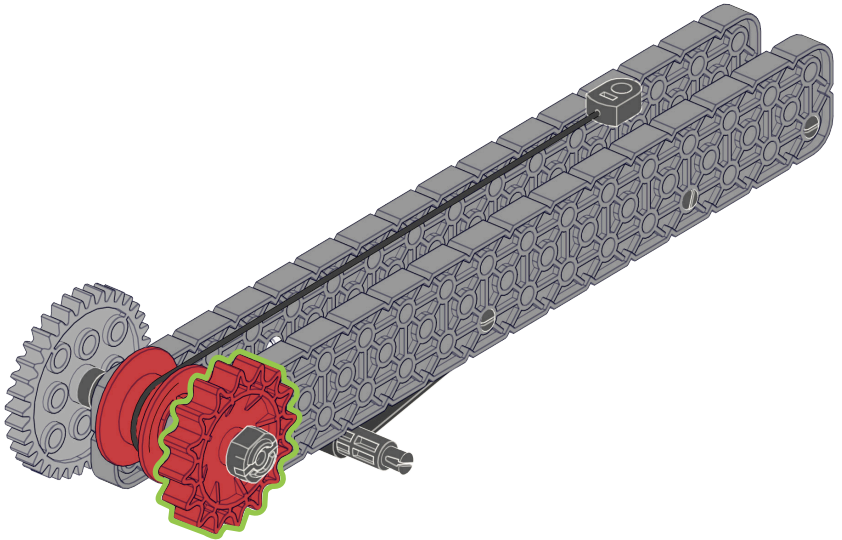
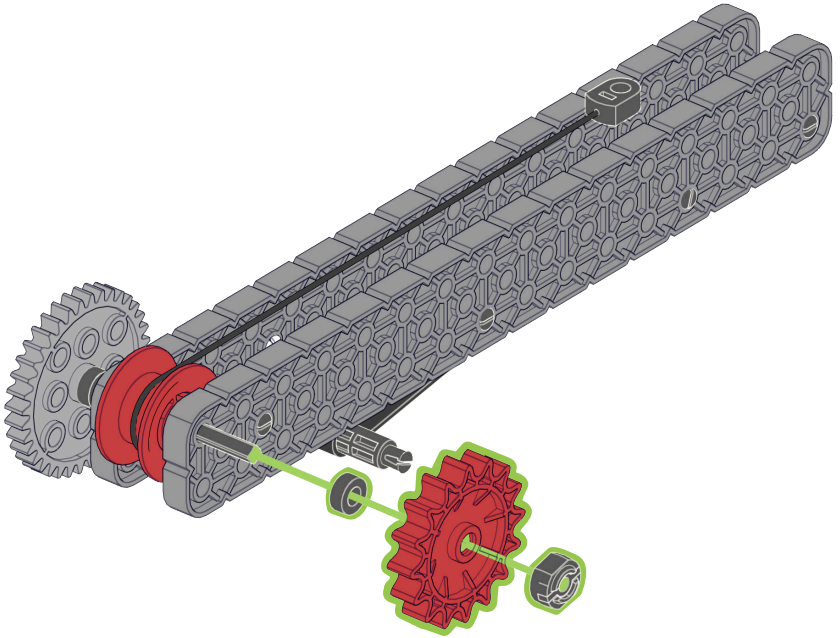

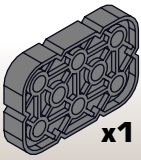

2x3

x1

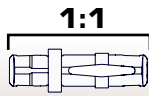

1:1

1x2

x2



1:1

1x1

x1

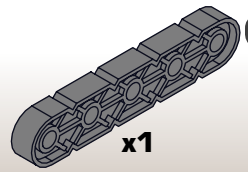

1x5

26

1

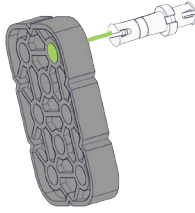

2

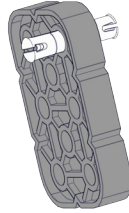

3

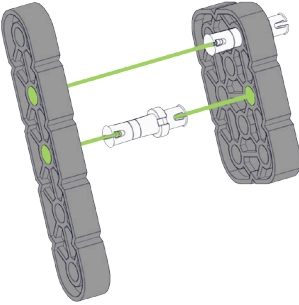

4

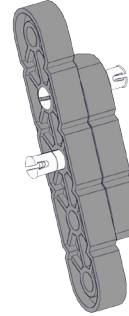

5

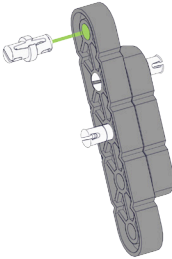

6

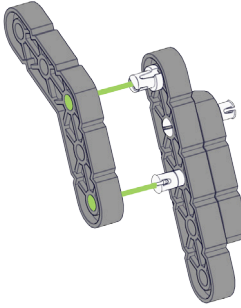

7

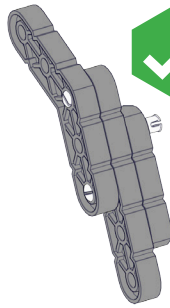

8

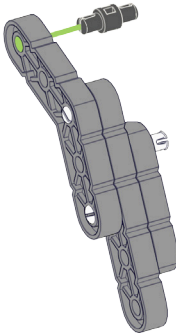

9

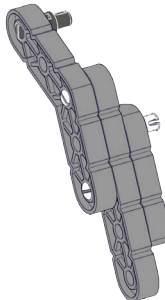



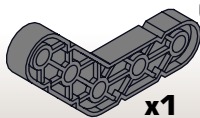

3x3 45°

x1



1:1

0.25

x1

27

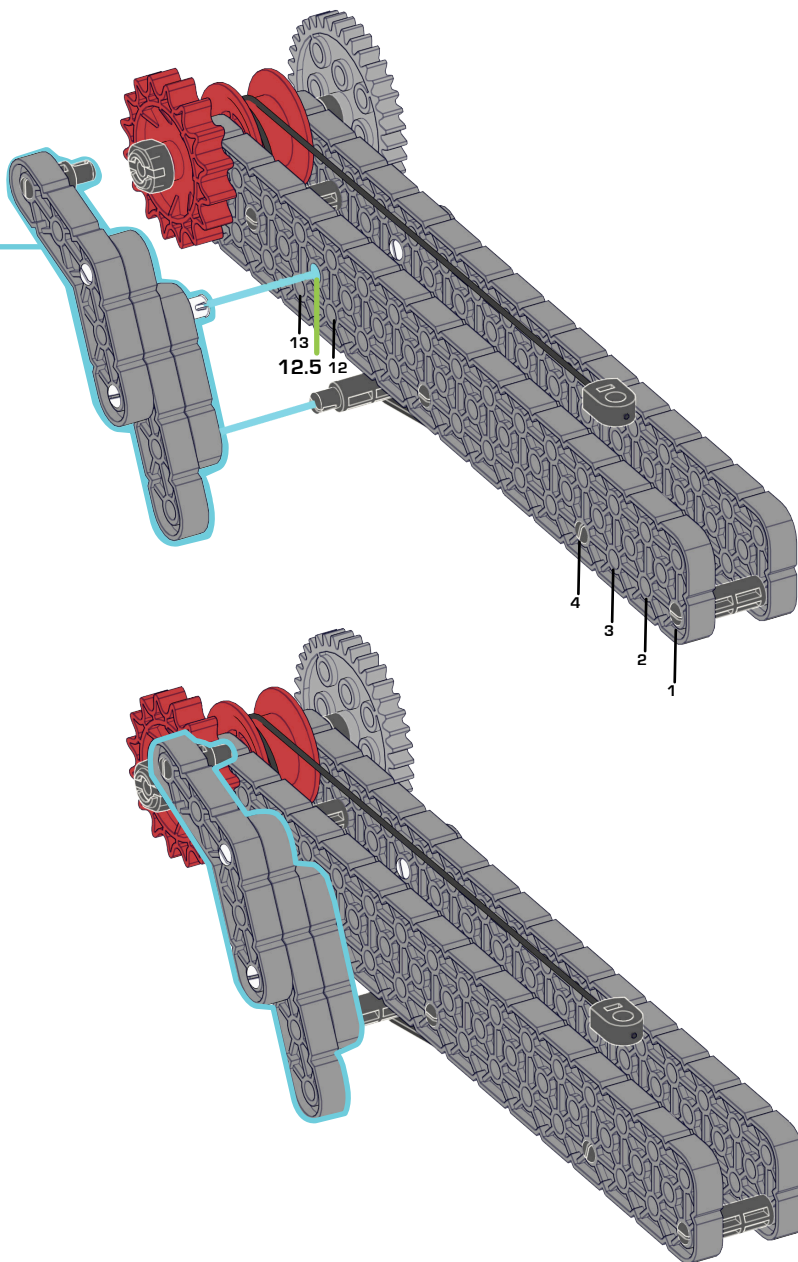

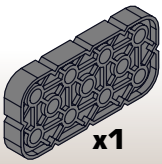

2x4

1:1

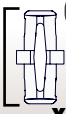

1x1



x1

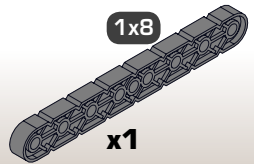

1x8

x1

28

1

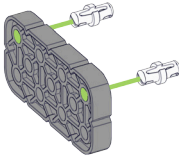

2

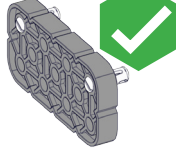

3

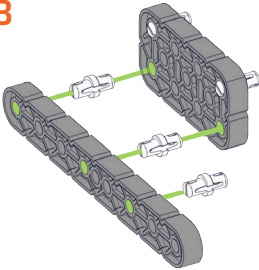

4

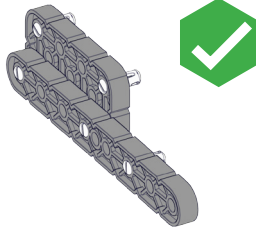

5

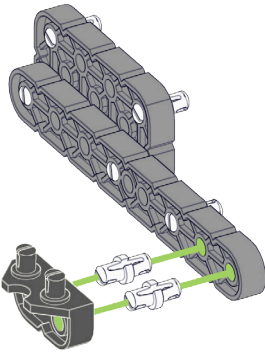

6

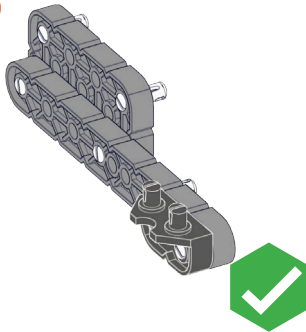

7

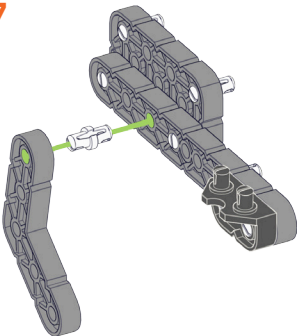

8

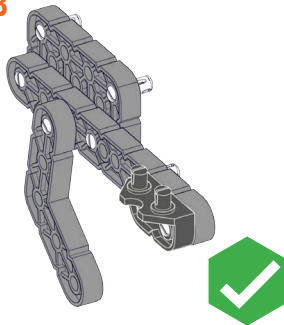

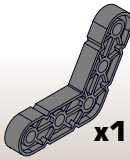

3x3 60°

x1

29

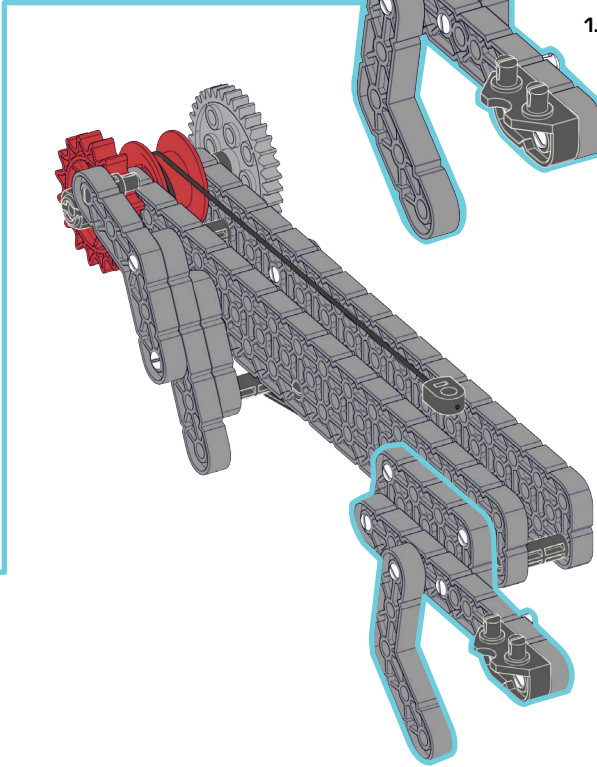
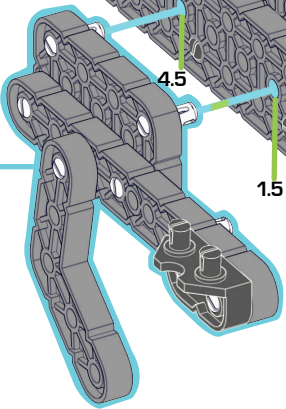
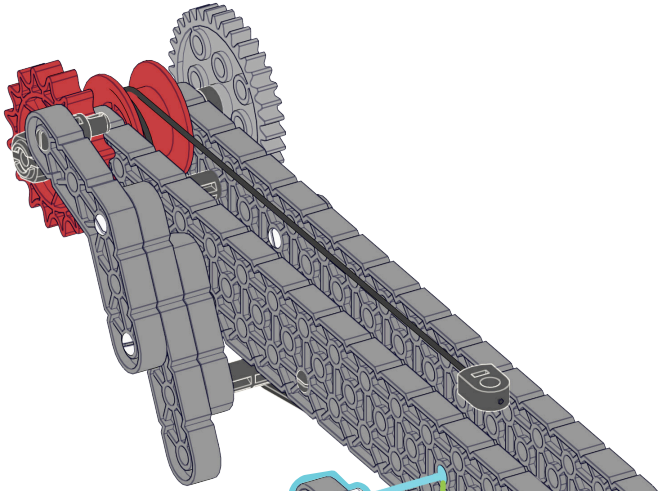

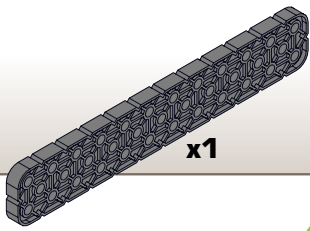

2x12

x1

1:1



1x1

x6

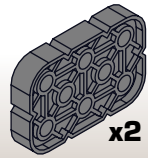

2x3

x2

30

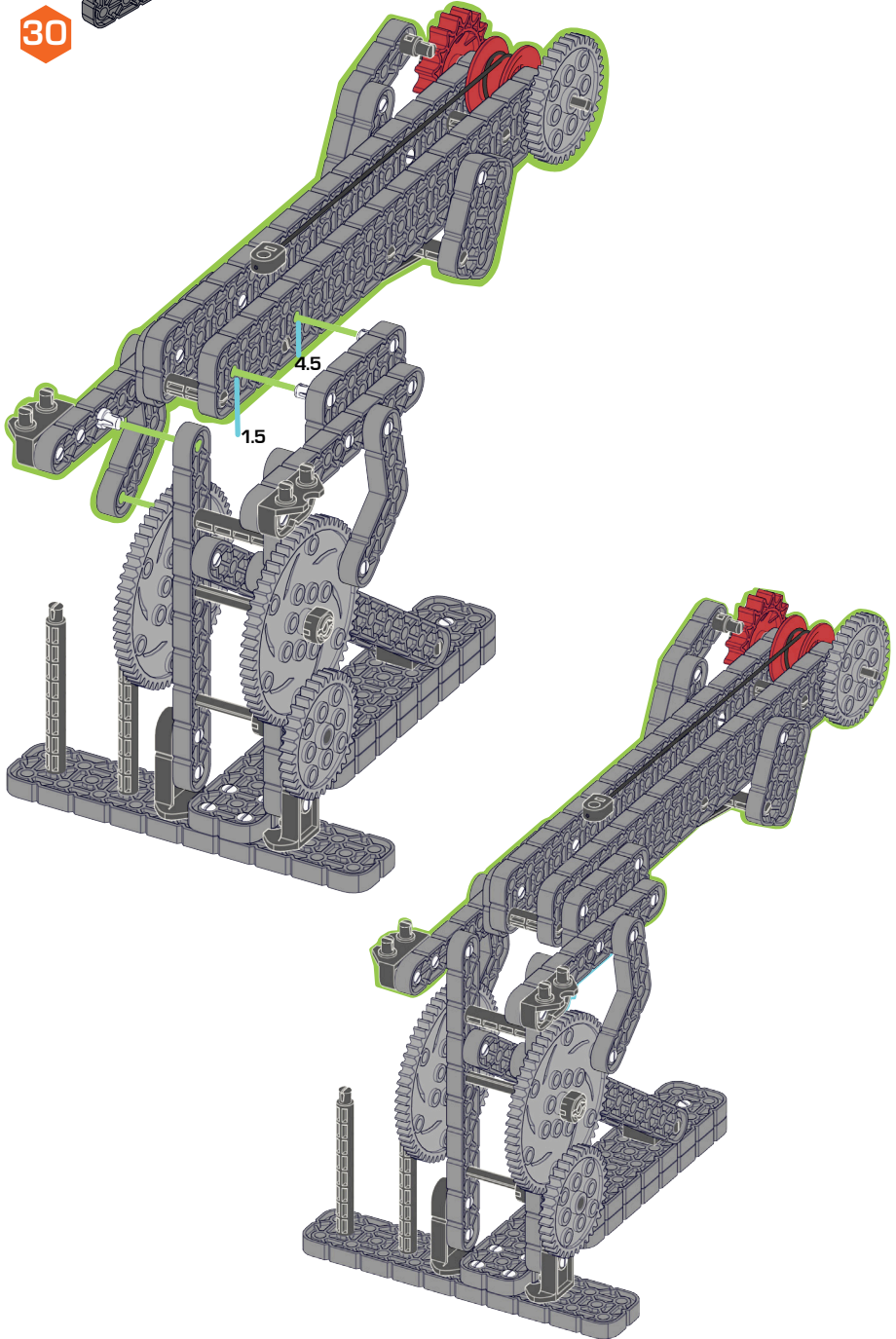

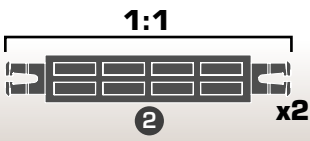

31

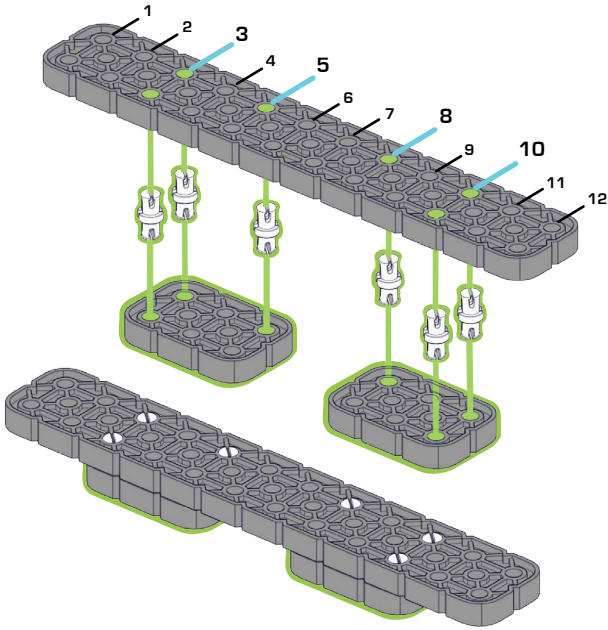

32

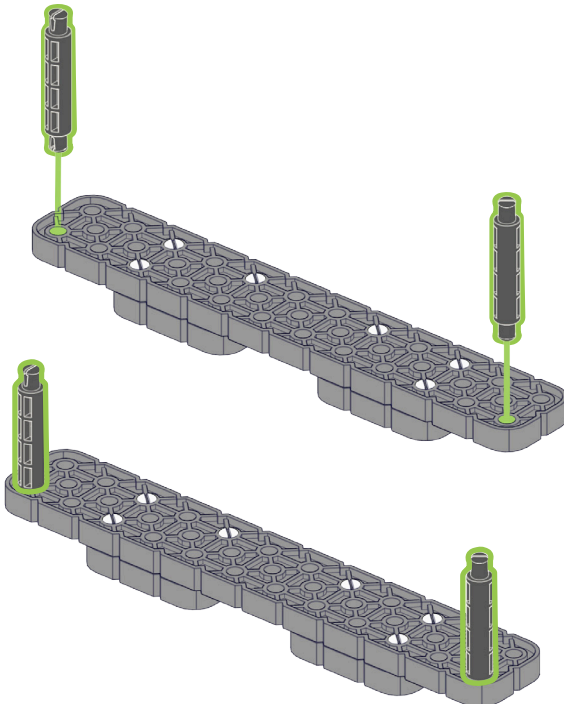

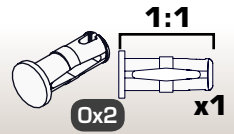
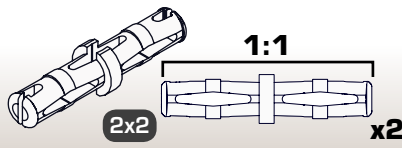
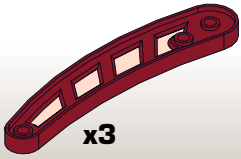

33

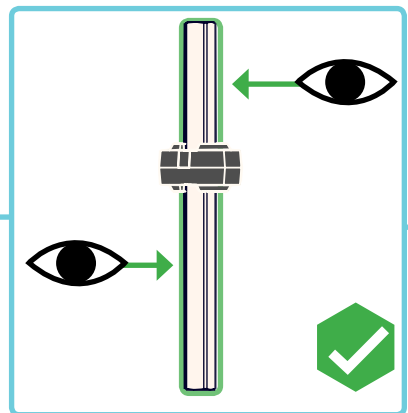
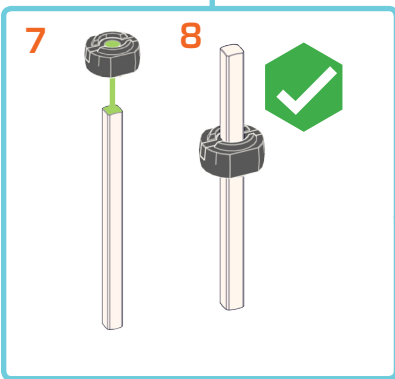
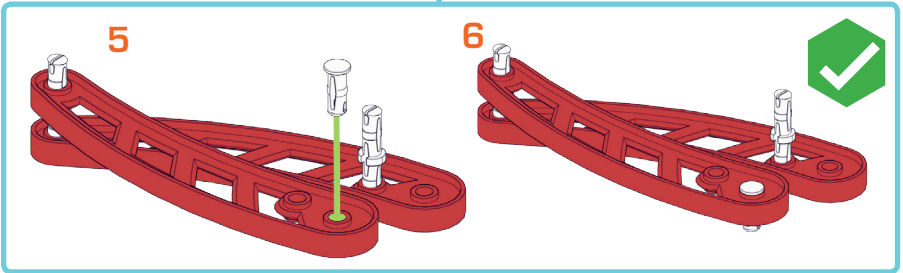
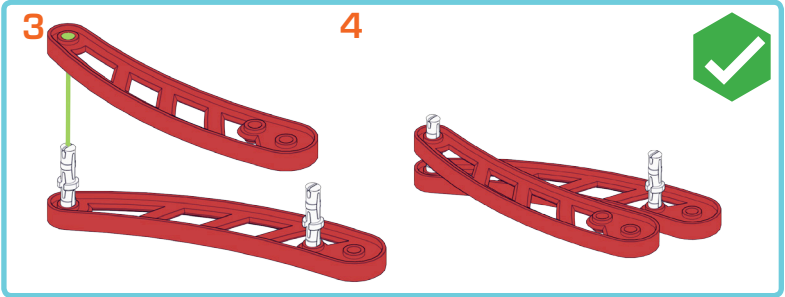
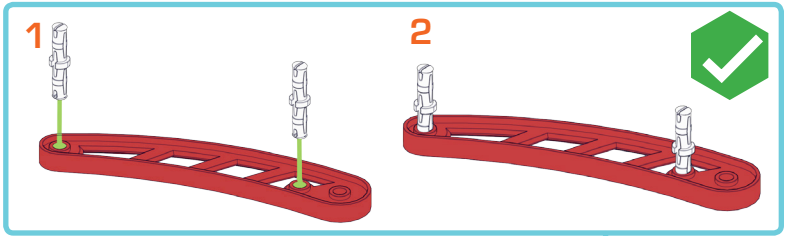



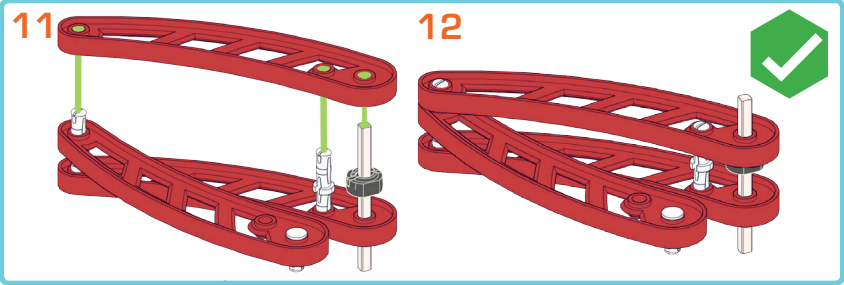
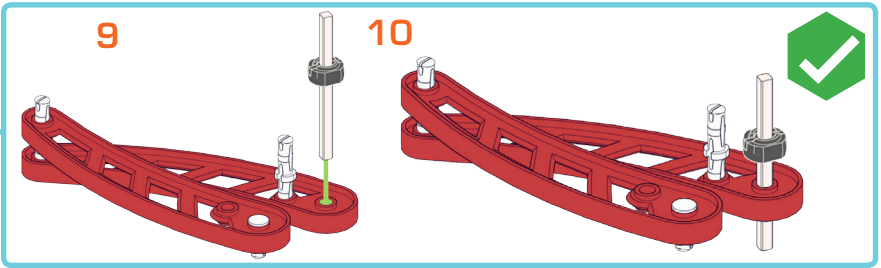
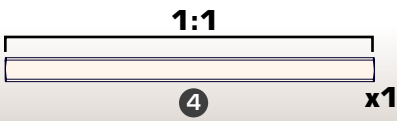

34

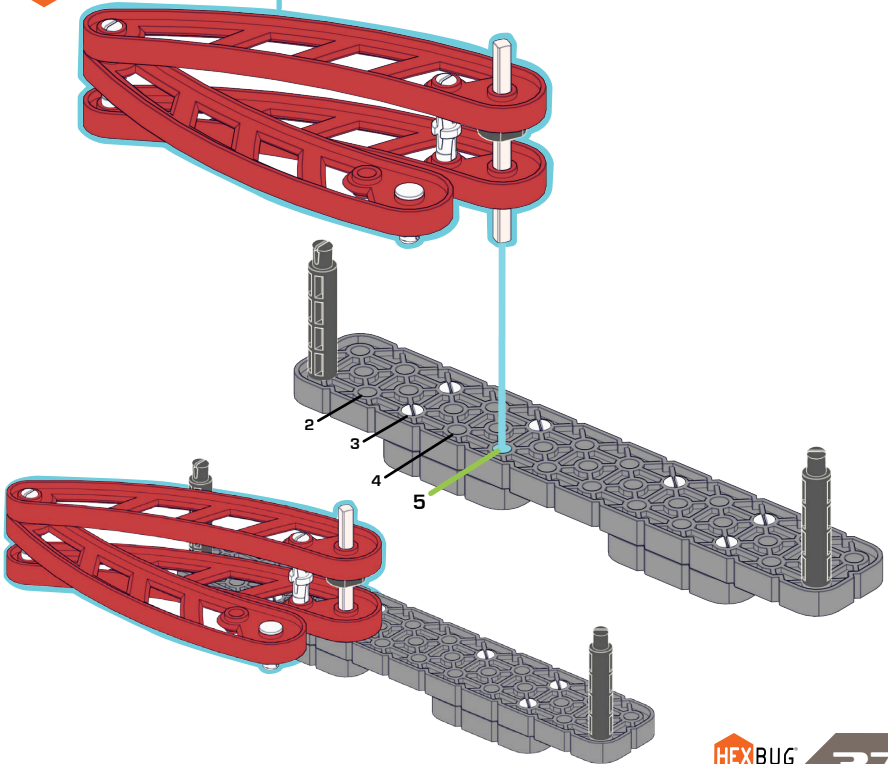

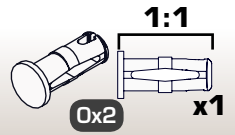
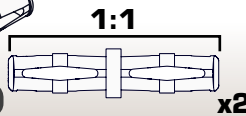
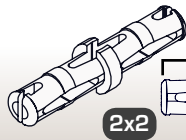
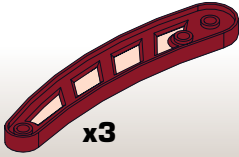

35

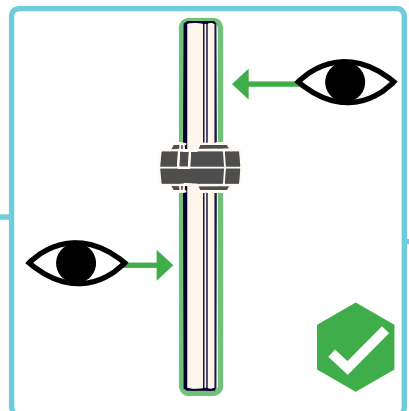
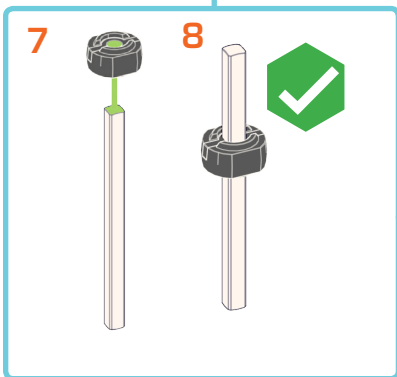
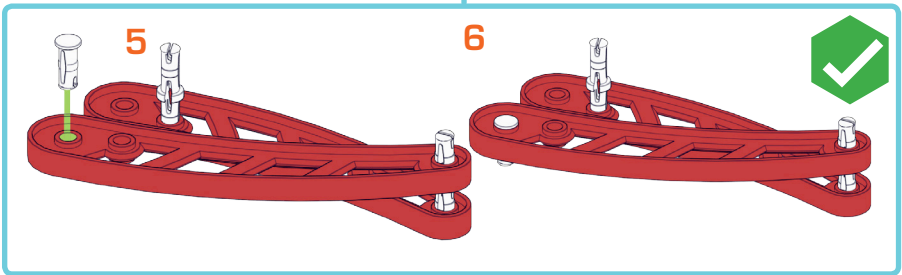
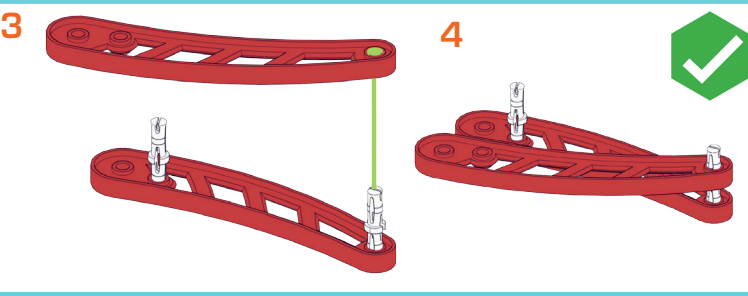
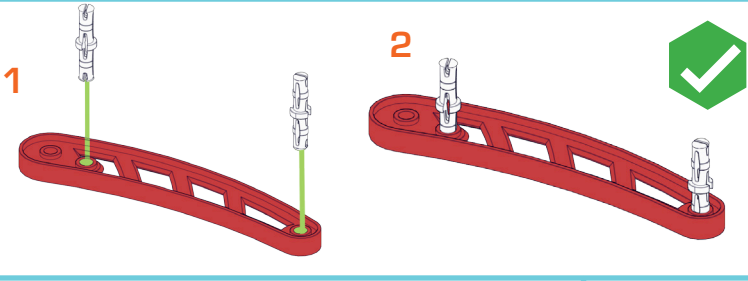

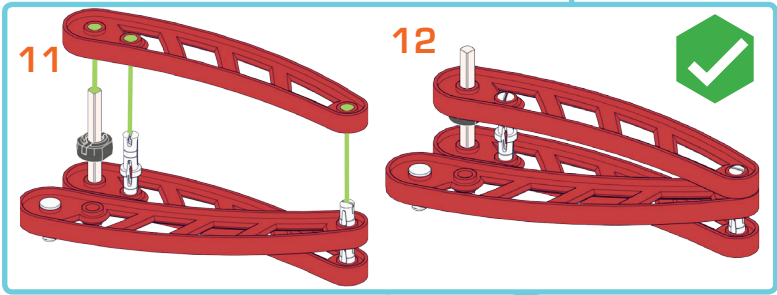
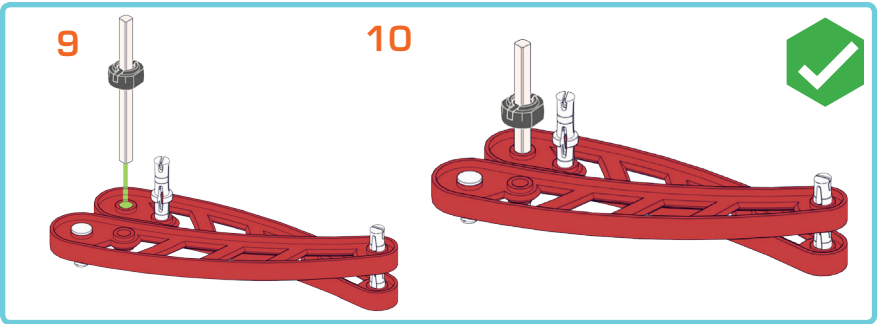
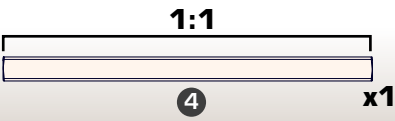

36

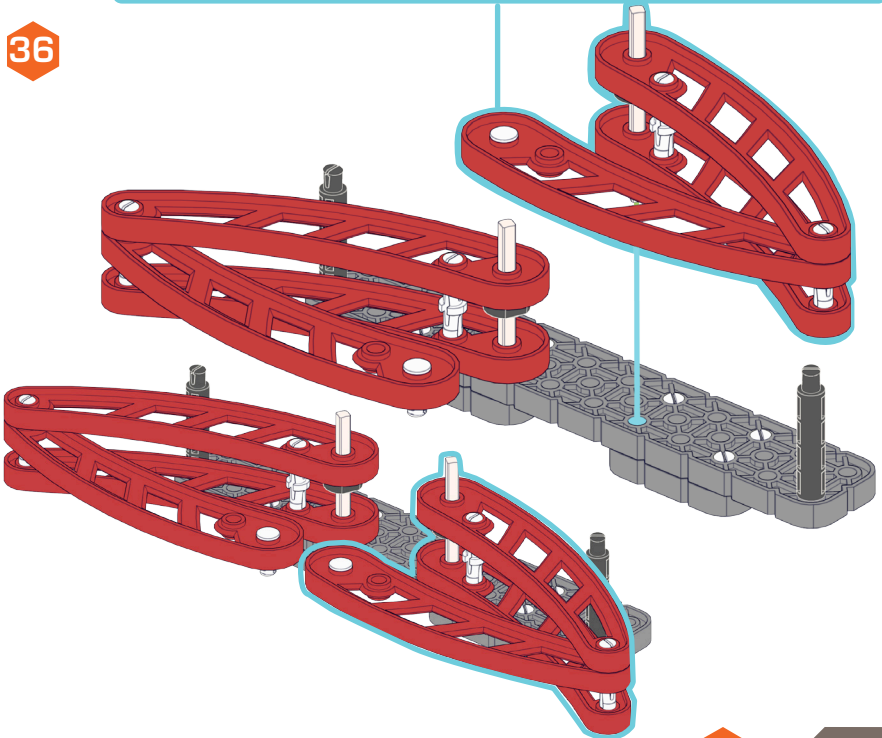

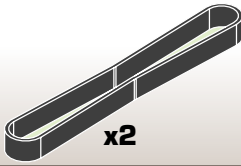

64

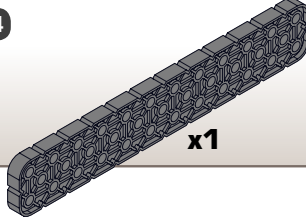

2x12

37

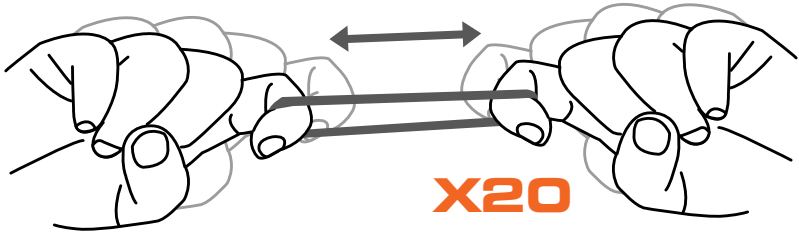

38

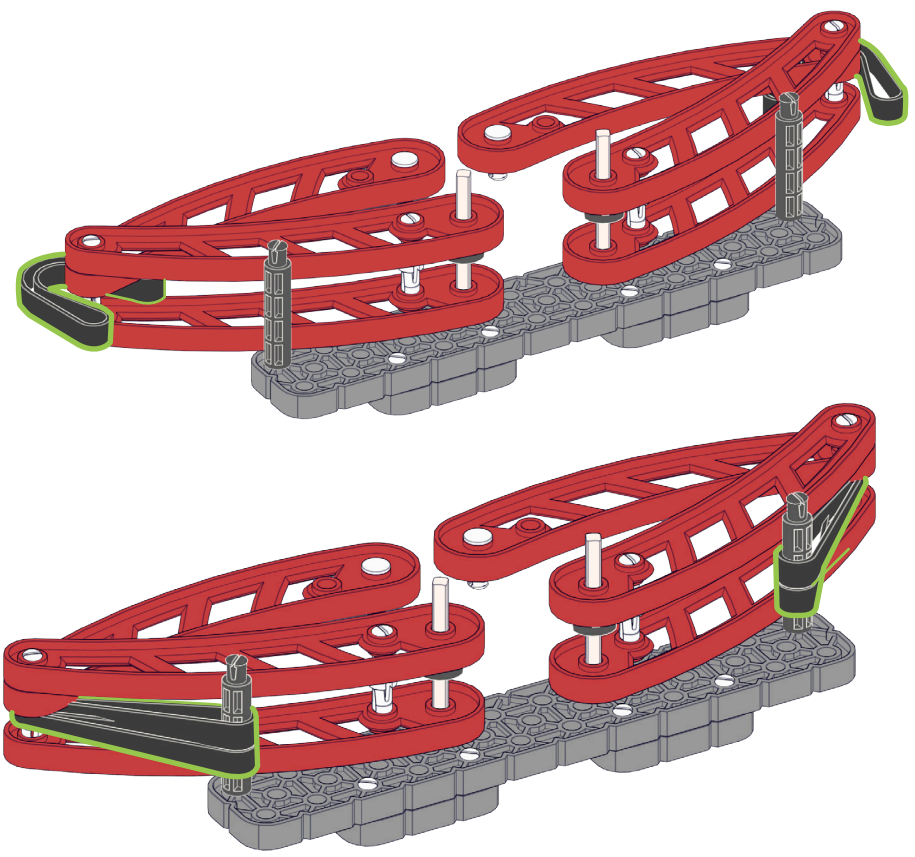

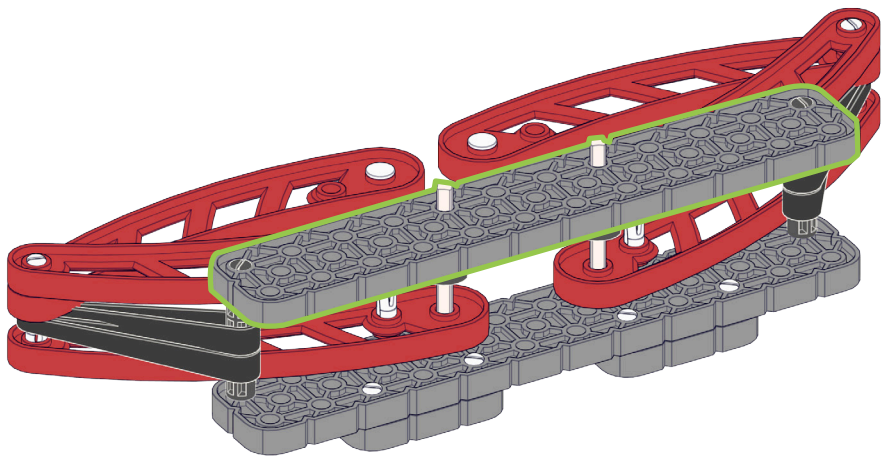
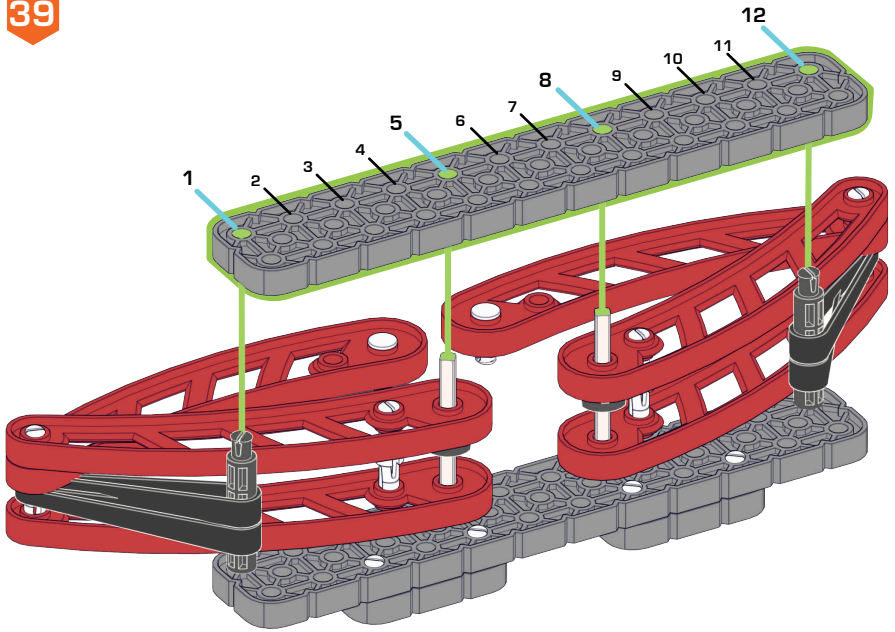

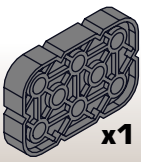

2x3

x1

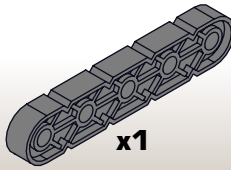

1x5

x1

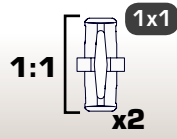

1:1

1x1

x2

40

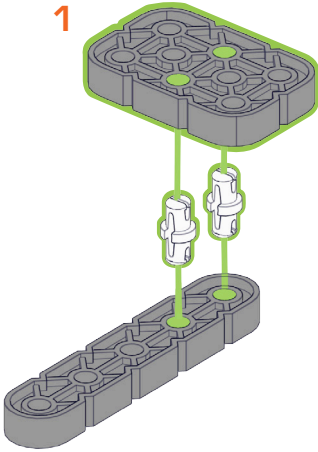

1

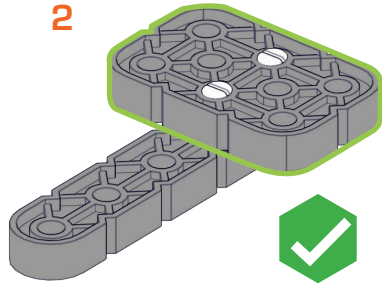

2

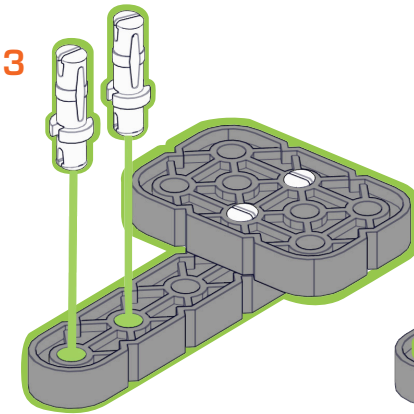

3

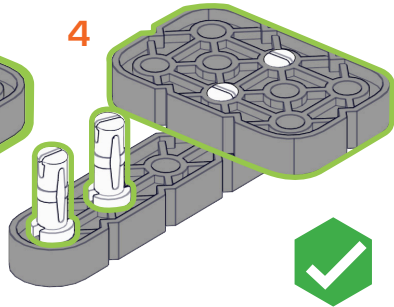

4



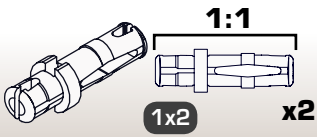

41

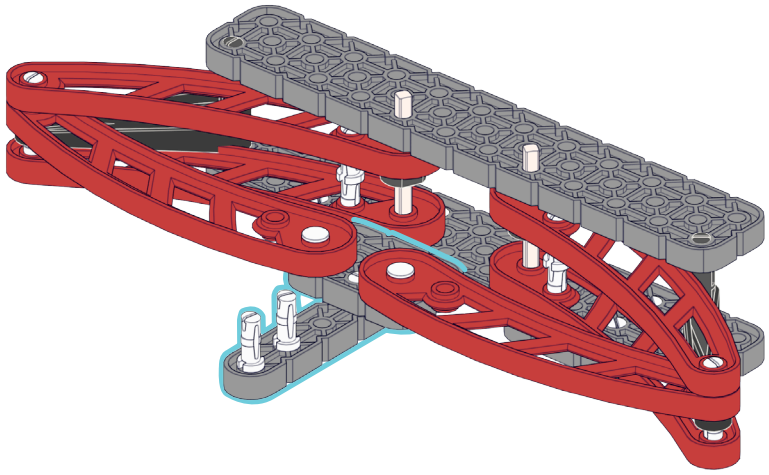
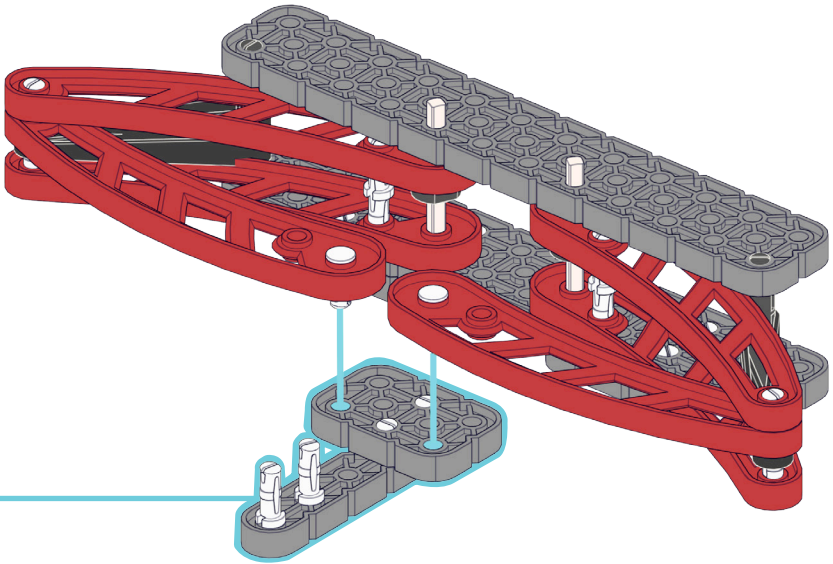

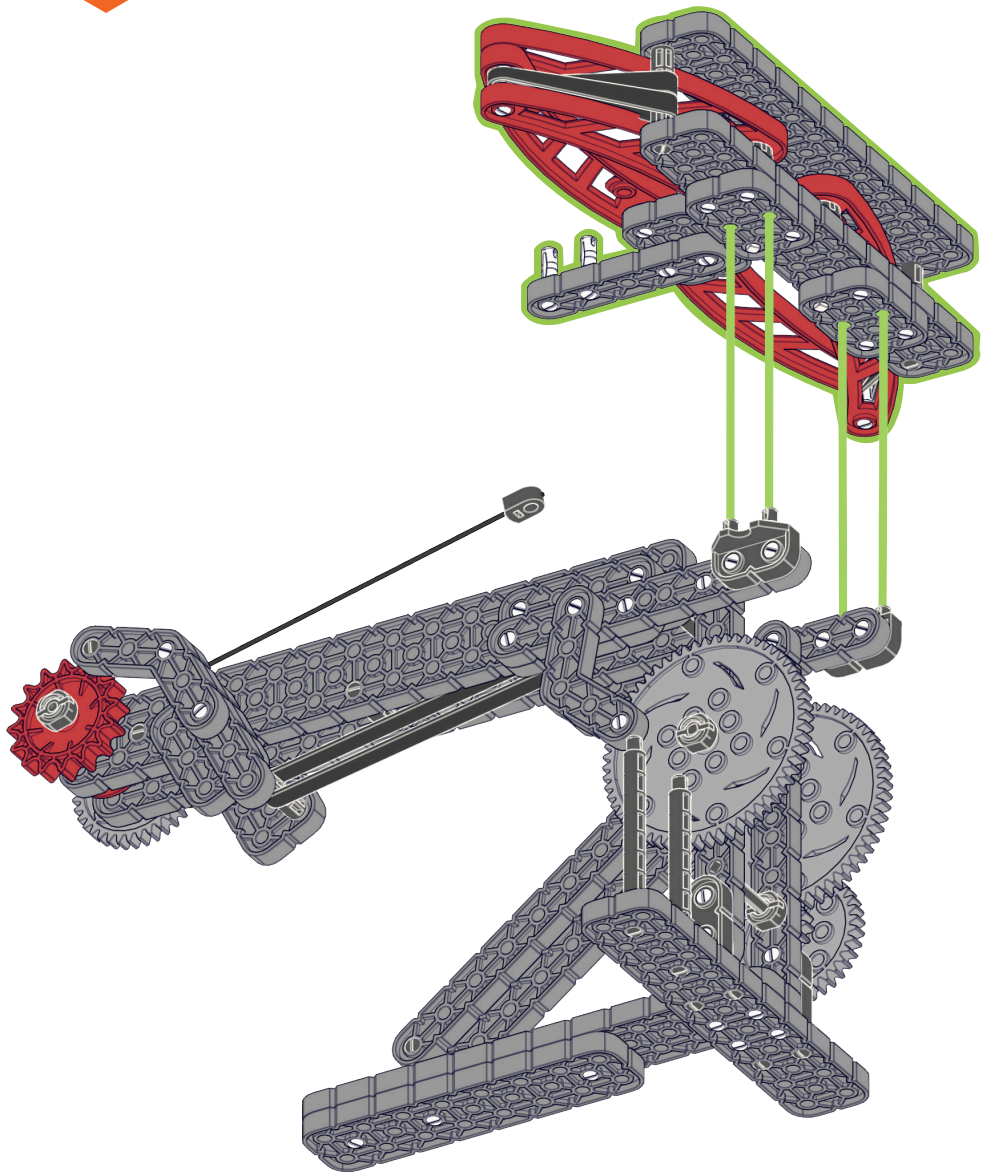

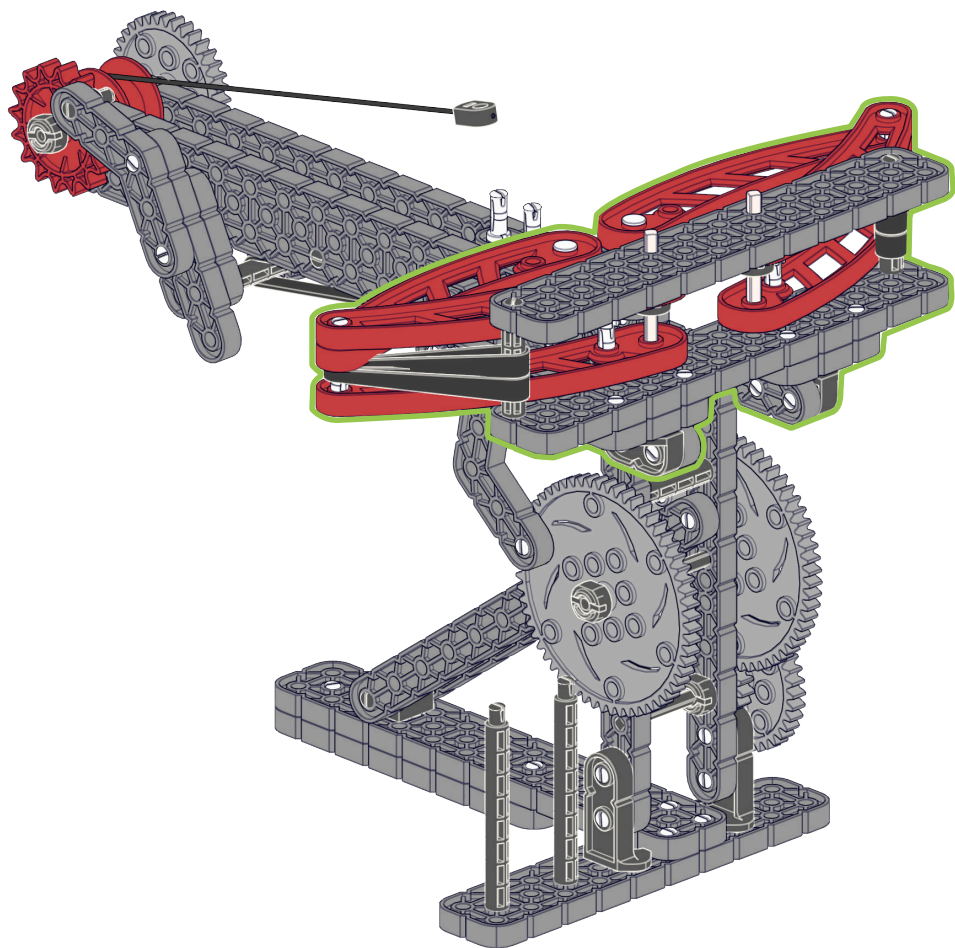

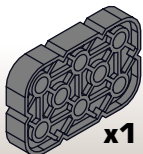

2x3

x1

43

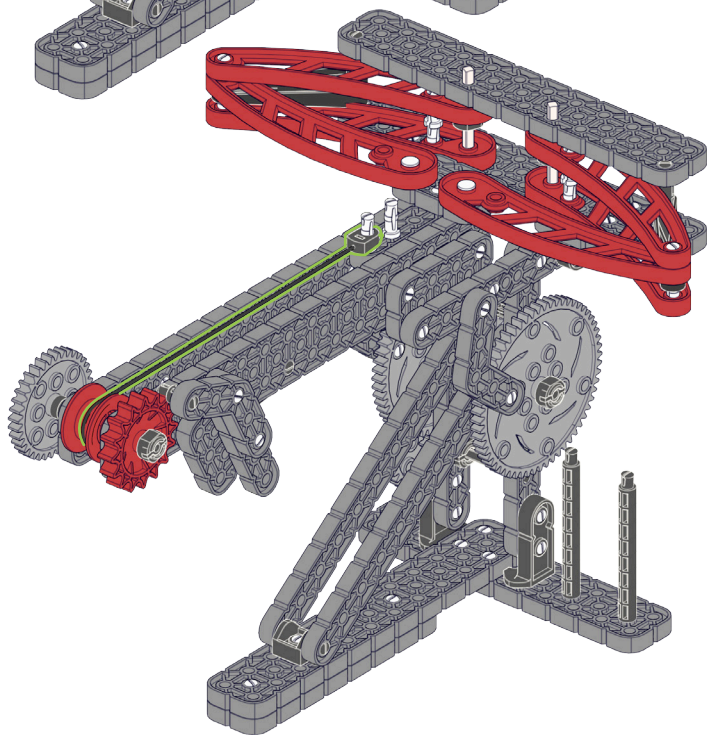
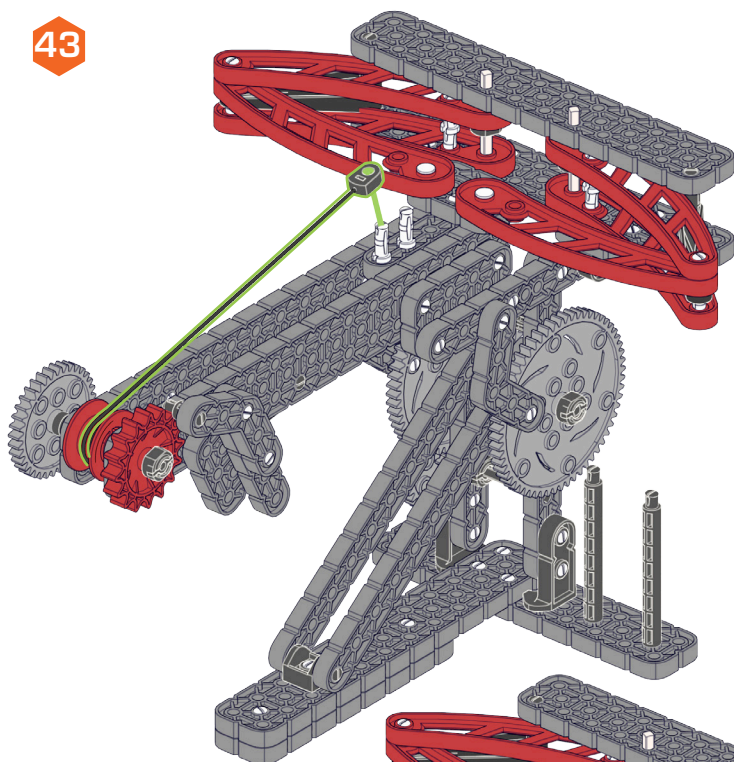



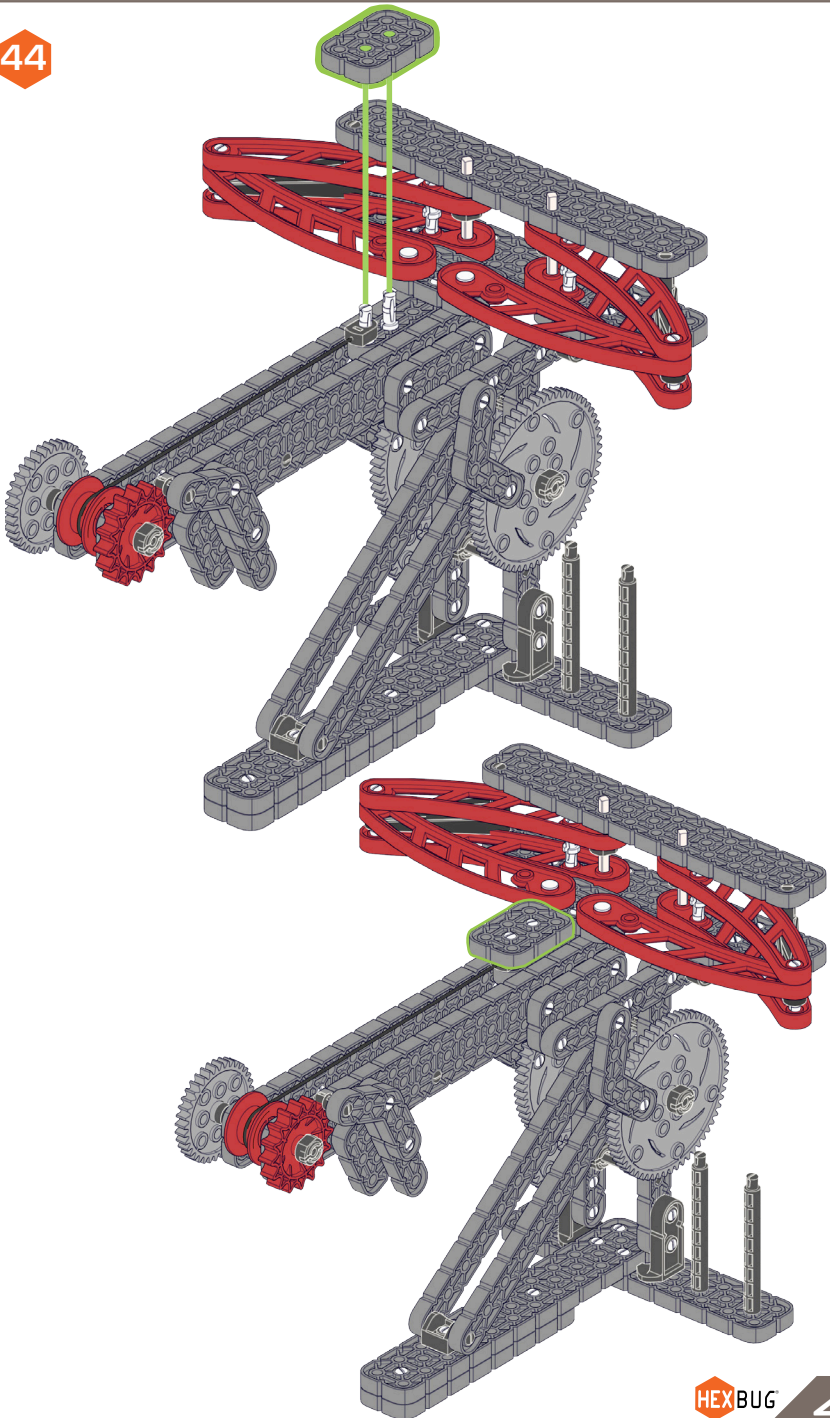

1:1  
1x1  
x4

x2

45

1

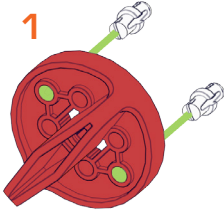

2

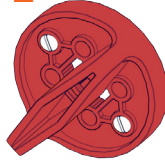

2X

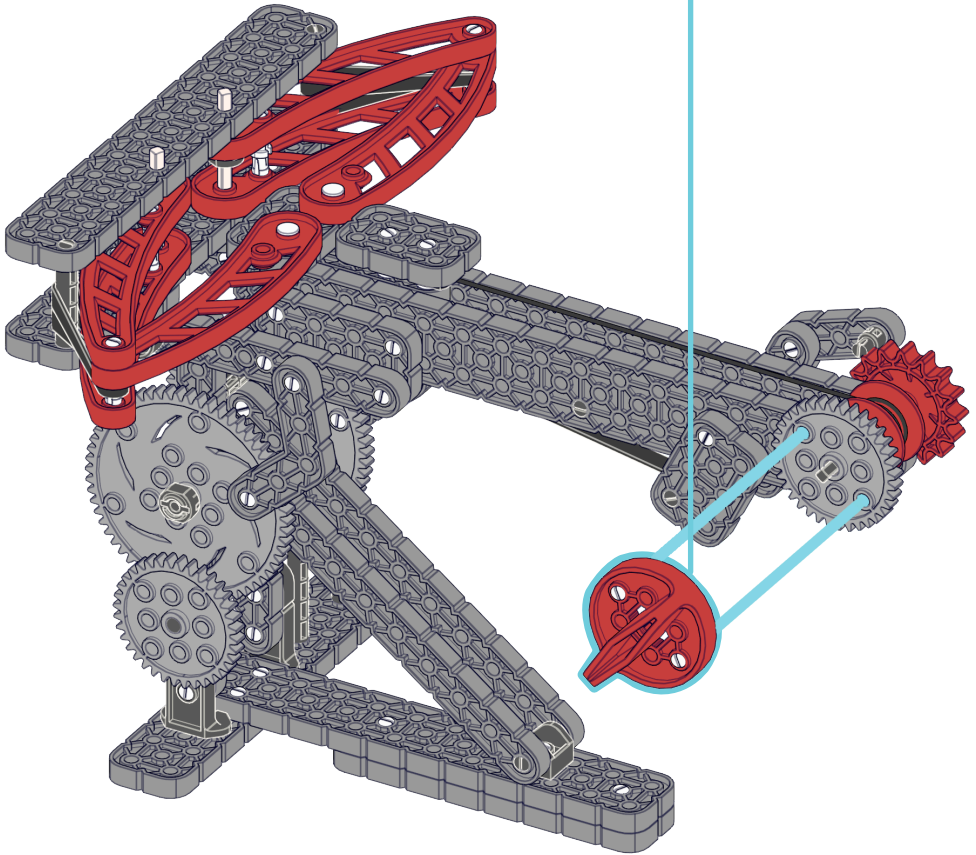



46

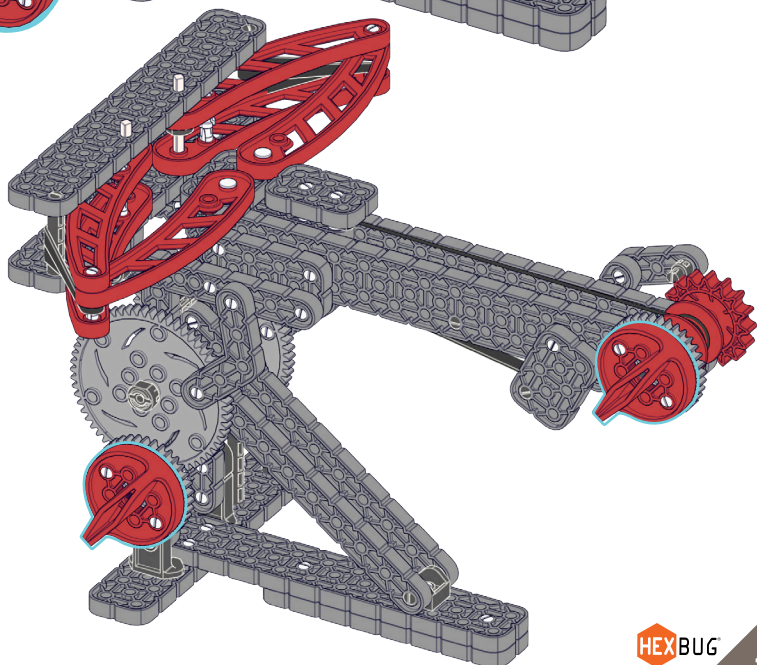
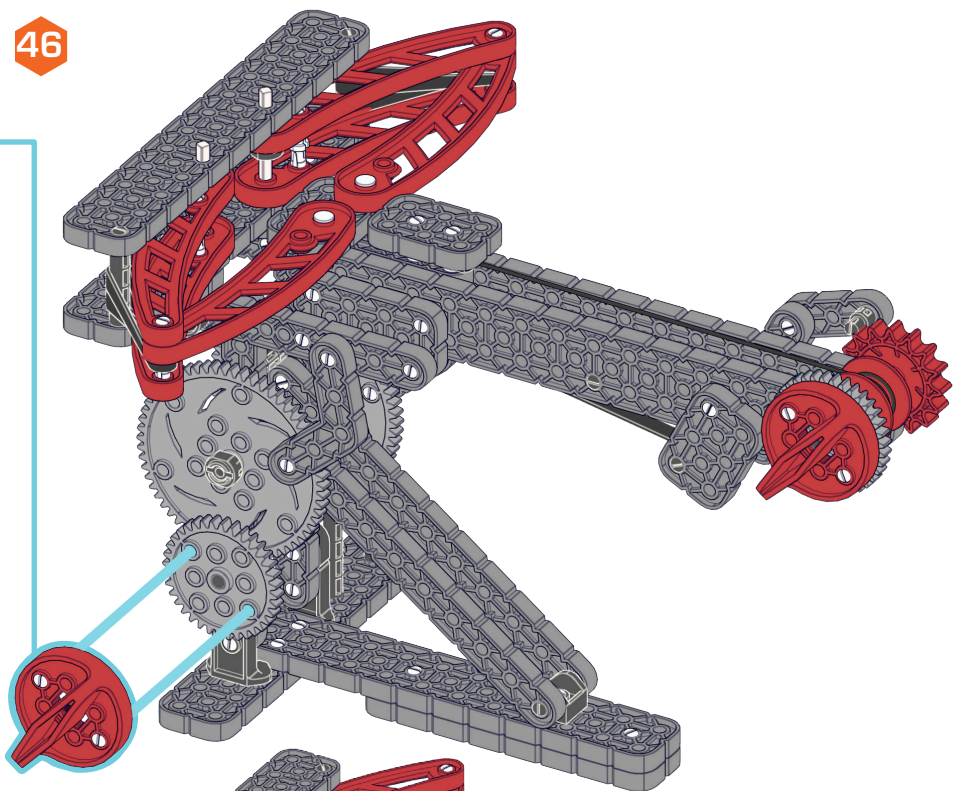

# HOW TO/ CÓMO/ COMMENT/ KURZANLEITUNG/

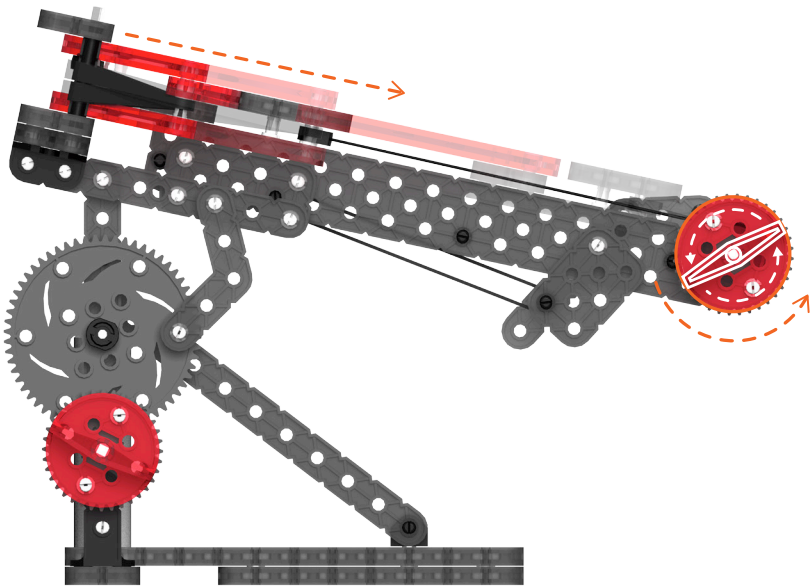
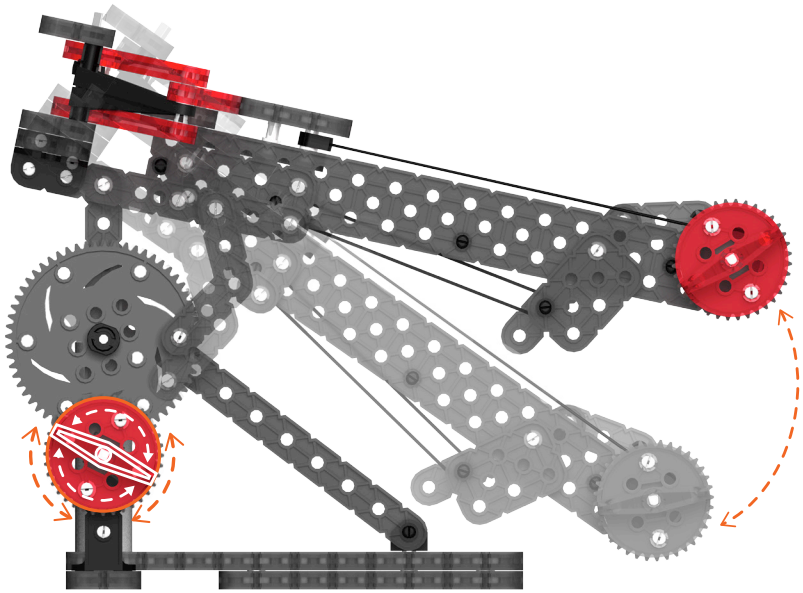

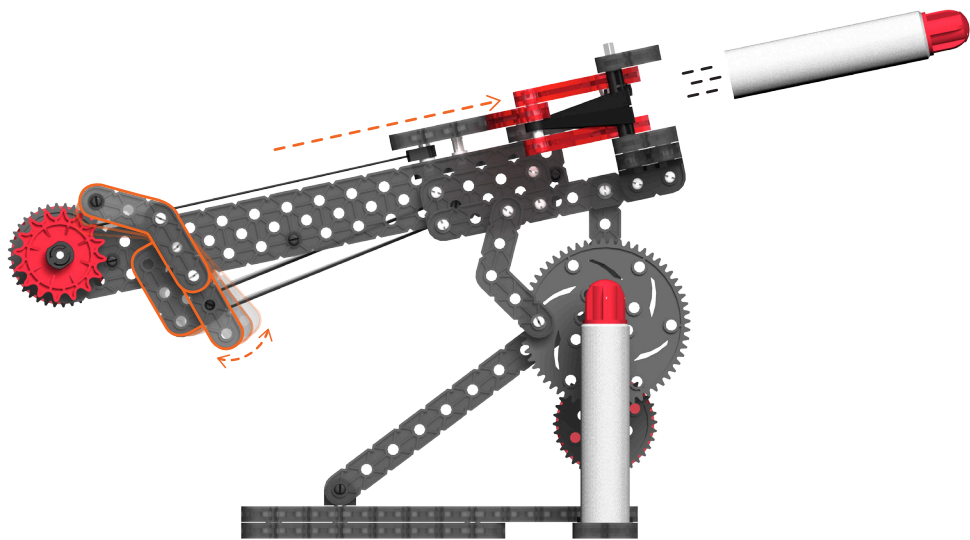
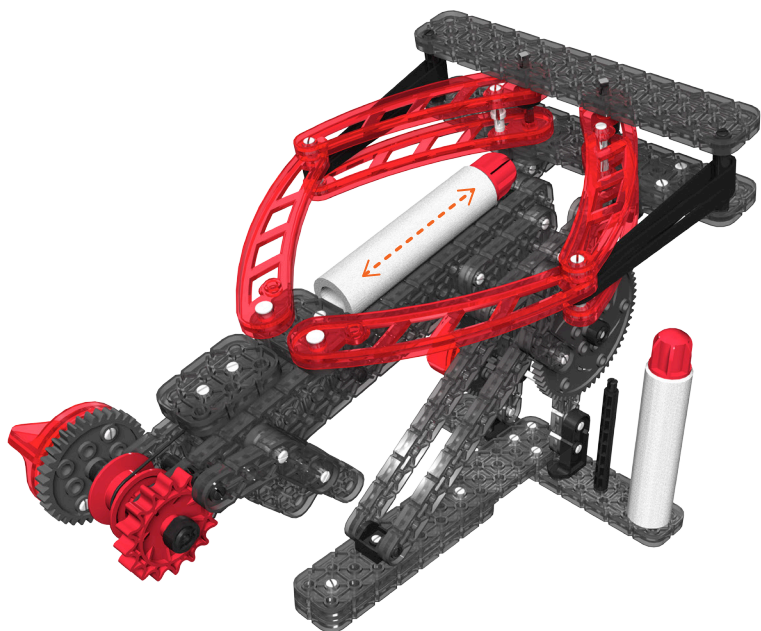

HEXBUG® / VEX® Robotics are registered trademarks of /sont des marques de commerce de/son marcas comerciales de/ist ein eingetragenes Warenzeichen von/zijn handelsmerken van/zijn handelsmerken van/ sono marchi di fabbrica di/ são marcas comerciais de Innovation First, Inc. DO NOT EAT HEXBUG®/ NE PAS MANGER HEXBUG®/NO COMER HEXBUG®/HEXBUG® IST NICHT ZUM VERZEHR BESTIMMT/HEXBUG® NIET ETEN/NON MANGIARE LA HEXBUG®/NÃO MASTIGUE AS BORRACHAS HEXBUG®. The item inside this package may vary from the photographs and /or illustrations. Please retain package for future reference. Please remove all packaging material before giving to children. This product conforms to the safety regulations. Patents and/or Patents Pending: innovation-first.com/patents./L'objet dans cet emballage peut différer des photographies et/ou des illustrations. Veuillez conserver cet emballage pour consultation ultérieure. Enlevez tout l'emballage avant de donner le jouet à des enfants. Ce produit est conforme aux normes de sécurité. Brevets et brevets en instance ou innovationfirst.com/patents./El artículo dentro de este empaque puede variar de las fotografías y/o ilustraciones. Conserve este empaque para futuras referencias. Retire todo el material de empaque antes de dar el juguete a los niños. Este producto cumple con las normas de seguridad. Patentes y patentes pendientes o innovationfirst.com/patents./Der in dieser Packung enthaltene Artikel kann von den Fotos und/oder Abbildungen abweichen. Bitte bewahren Sie die Verpackung auf, damit Sie später ggf. auf diese Informationen zurückgreifen können. Entfernen Sie sämtliche Verpackungsmaterialien, ehe Sie das Spielzeug einem Kind aushändigen. Dieses Produkt entspricht den Sicherheitsbestimmungen. Patente oder zum Patent angemeldet und innovation-first.com/patents./L'articolo all'interno della confezione può non essere identico alle fotografie e/o illustrazioni. Conservare la confezione per riferimento futuro. Rimuovere tutti i materiali da imballaggio prima di consegnare a bambini. Questo prodotto è conforme alle norme di sicurezza. Brevetti o brevetti in attesa di innovationfirst.com/patents.

MADE AND ASSEMBLED IN CHINA./FABRIQUÉ ET ASSEMBLÉ EN CHINE./FABRICADO Y ENSAMBLADO EN CHINA./HERSTELLUNG UND MONTAGE IN CHINA./FABBRICATO E MONTATO IN CINA.

Custom manufactured in China for Innovation First Trading SARL. Distributed in the U.S.A. by Innovation First Labs, Inc., 1519 Interstate 30 West, Greenville, Texas 75402, U.S.A. Distributed in Europe by Innovation First Trading SARL, 21b rue Gabriel Lippmann, L-5365 Munsbach, Luxembourg +352 27 86 04 87. Distributed in Canada/Distribué au Canada par/by Innovation First Trading, Inc., 1519 Interstate 30 West, Greenville, Texas 75402, U.S.A. [www.hexbug.com/contact](http://www.hexbug.com/contact)

PLEASE KEEP THESE INSTRUCTIONS. Veuillez conserver le mode d'emploi./Por favor conserve la guía de instrucciones./Diese Anleitung bitte aufbewahren./Conservare queste istruzioni.



Copyright © 2016 Innovation First, INC. All Rights Reserved./Tous droits réservés.

**CAUTION:**  
Do not aim at eyes or face. TO AVOID INJURY: Use only projectiles designed for this product.  
Do not modify projectiles or projectile launcher.

**ATTENTION:**  
Ne pas viser les yeux ou le visage. POUR EVITER TOUTES BLESSURES: Utilisez uniquement des projectiles conçus pour ce produit. Ne pas modifier les projectiles ou le lanceur de projectiles.



- ⚠ Warning: CHOKING HAZARD – Small parts.
- ⚠ Avertissement: RISQUE D'ASPHYXIE – Ce produit contient de petits éléments.
- ⚠ Advertencia: RIESGO DE ASFIXIA – Contiene piezas pequeñas.
- ⚠ Achtung: ERSTICKUNGSGEFAHR – Kleinteile.
- ⚠ Attenzione: RISCHIO DI SOFFOCAMENTO – Pezzi piccoli.









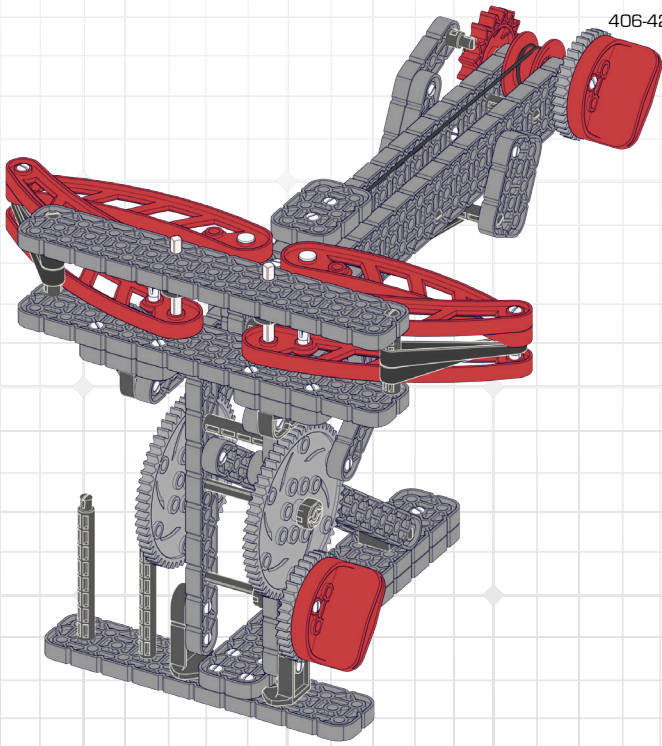

**VEX**<sup>®</sup>  
ROBOTICS

NEED HELP?

¿NECESITAS AYUDA?

BESOIN D'AIDE?

SERVE AIUTO??

HILFE?

HULP NODIG?

POTRZEBUJESZ POMOCY?

[WWW.VEX.COM/HELP](http://WWW.VEX.COM/HELP)