

Magnetic Wireless Qi Charging Phone Mount

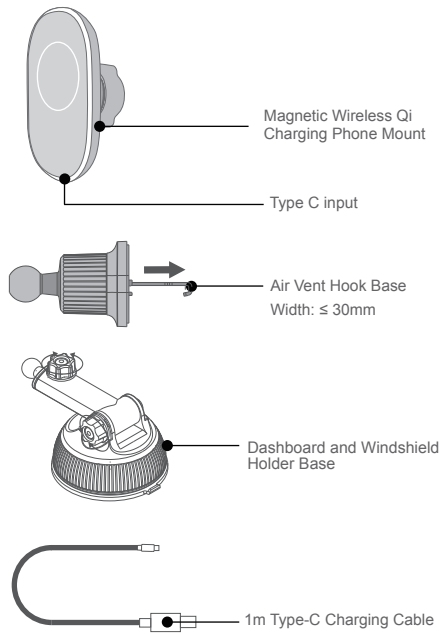

Instruction Manual



SPECIFICATIONS:

- Input: DC 5V2A, 9V2.22A
- Output: DC 5V/1A, 7.5V/1A, 9V/1.12A, 9V/1.66A (5W, 7.5W, 10W, 15W)
- Transmission distance: ≤5mm
- Charging efficiency: 75% Max

TIPS:

- Only for iPhone 13/12 Series (MagSafe® Case Friendly): iPhone® 13 / iPhone® 12, iPhone® 13 Pro / iPhone® 12 Pro, iPhone® 13 Pro Max / iPhone® 12 Pro Max, iPhone® 13 Mini / iPhone® 12 Mini
- Note: Please use case with official MagSafe® case or the metal ring. Not compatible with other phone cases!
- Works with all Qi-enabled phones: Smartphones, iPhone®, Google Pixel, Samsung Galaxy.
- Note: Please use our adaptive metal ring for your Qi-enabled phones.
- Note: Adaptive metal ring is only compatible when placed externally on the smart phone.

HOW TO USE WIRELESS CHARGING:

Unscrew the mounting ring, insert the ball through the mounting ring, then position to your preferred angle and tighten the ring to secure the mount.

Please tear off the protective film before using.

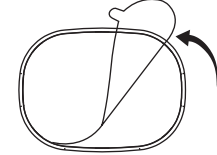

With MagSafe® Compatible Devices

*Up to 7.5W wireless charging for iOS® devices.

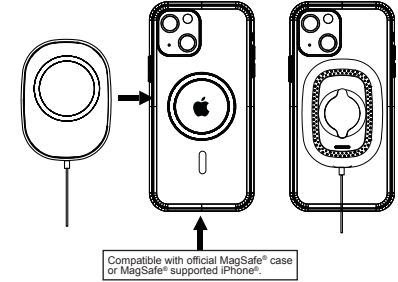

NOTE:

1. Please Use Case with Magsafe® Or Use Our Magnet Ring with Case
2. Please Use QC3.0 Car Charger

Attention : If you have not purchased a MagSafe® case, please install our magnet ring on the back of the phone.

Ring Magnet *Up to 15W wireless charging for Android devices.

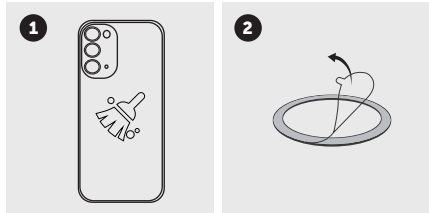

Clean the phone/case before installing Remove the protective film and stickers

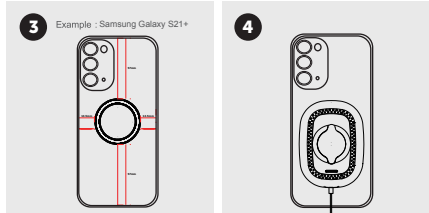

Please stick the magnetic ring in the middle of the phone/case

Air Vent Mount:

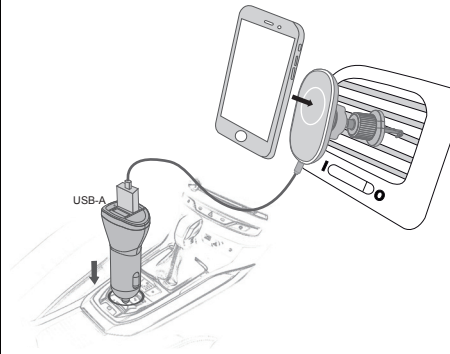
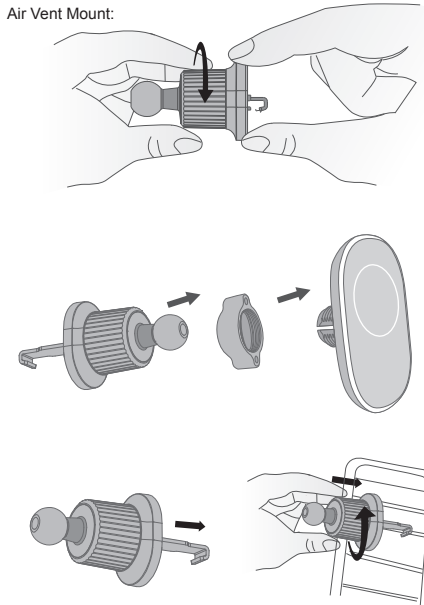

QC 3.0 Car Charger not included.

Distributed by:
Electus Distribution Pty. Ltd.
320 Victoria Rd, Rydalmere
NSW 2116 Australia

www.electusdistribution.com.au

Made in China