

digitech



User Manual
100W 8-Channel PA System
with Wireless Microphones

CS2566

CONTENTS

Section 1: Important Safety Instructions

Section 2: Precautions

Section 3: The System Power Amplifier

Section 4: Introduction to the PA System

Section 5: System Specifications

Section 6: Trouble Shooting

SECTION 1: IMPORTANT SAFETY INSTRUCTIONS

1. Read these instructions.
2. Keep these instructions.
3. Keep all warnings.
4. Follow all instructions.
5. Do not use this apparatus near water.
6. Clean only with dry cloth.
7. Do not block any ventilation openings. Install in accordance with the manufacturer's instructions.
8. Do not install near any heat sources such as radiators, heat registers, stoves, or other apparatus (including amplifiers) that produce heat.
9. Protect the power cord from being walked on or pinched, particularly at plugs, convenience receptacles, and the point where they exit from the apparatus.
10. Only use attachments/accessories specified by the manufacturer.
11. Unplug this apparatus during lightning storms or when unused for a long period of time.
12. Refer all servicing to qualified service personnel. Servicing is required when the apparatus has been damaged in any way, such as power supply cord or plug is damaged, liquid has been spilled or objects have fallen into the apparatus, the apparatus has been exposed to rain or moisture, does not operated normally, or has been dropped.
13. To completely disconnect this apparatus from the AC mains, disconnect the power supply cord plug from the AC receptacle.
14. **WARNING! TO REDUCE THE RISK OF FIRE OR ELECTRIC SHOCK, DO NOT EXPOSE THIS APPARATUS TO RAIN OR MOISTURE.**
15. Do not expose this equipment to dripping or splashing and ensure that no objects filled with liquids, such as vases, are placed on the equipment.
16. The mains plug of the power supply cord shall remain readily operable.

CARE & CLEANING

The systems may be cleaned with a dry cloth. Do not get moisture into any of the openings in the system. Ensure that the system is unplugged from the AC outlet before cleaning.

THIS APPARATUS CONTAINS POTENTIALLY LETHAL VOLTAGES. TO PREVENT ELECTRIC SHOCK OR HAZARD, DO NOT REMOVE CHASIS, MIXER MODULE OR AC INPUT COVERS. NO USER SERVICEABLE PARTS INSIDE. REFER SERVICING TO QUALIFIED SERVICE PERSONNEL.

SECTION 2: PRECAUTIONS

The system covered by this manual is not intended for use in high moisture environments. Moisture can damage the speaker cone and surround and cause corrosion of electrical contacts and metal parts. Avoid exposing the speakers to direct moisture. Keep speakers out of extended or intense direct sunlight. The driver suspension will prematurely dry out and finished surfaces may be degraded by long-term exposure to intense ultra-violet (UV) light. The system can generate considerable energy. When placed on a slippery surface such as polished wood or linoleum, the speaker may move due to its acoustical energy output. Precautions should be taken to assure that the speaker does not fall off a stage or table when it is placed.

STAND MOUNTING SAFETY PRECAUTIONS

The speakers contain a 36mm receptacle cup to allow mounting on tripod stands or on a pole over subwoofers. When using stands or poles, be sure to observe the following precautions:

- Check the stand or pole specification to be certain the device is designed to support the weight of the speaker. Observe all safety precautions specified by the manufacturer.
- Always verify that the stand (or subwoofer/pole) is placed on a flat, level and stable surface and be sure to fully extend the legs of tripod-type stands. Position the stand so that the legs do not present a trip hazard.
- Route cables so that performers, production crew, and audience will not trip and topple the speakers over.
- Inspect the stand (or pole and associated hardware) before each use and do not use equipment with worn, damaged or missing parts.

- Do not attempt to place more than one series speaker on a stand or pole.
- Always be cautious in windy, outdoor conditions. It may be necessary to place additional weight (e.g. sandbags) on the base of the stand to improve stability. Avoid attaching banners or similar items to any part of a speaker system. Such attachments could act as a sail and topple the system.
- Unless you are confident that you can handle the weight of the speaker, ask another person to help you get it onto the tripod stand or pole.

HEARING DAMAGE, PROLONGED EXPOSURE TO EXCESSIVE SPL

WATCH FOR THESE SYMBOLS!

The exclamation point within an equilateral triangle is intended to alert the user to the presence of important operating and maintenance (Servicing) instructions in the literature accompanying the product.

The lightning flash with the arrowhead symbol within an equilateral triangle is intended to alert the user to the presence of un-insulated “Dangerous Voltage” within the products enclosure that may be of sufficient magnitude to constitute a risk of electric shock to persons.



SECTION 3: THE SYSTEM POWER AMPLIFIER

AC POWER REQUIREMENTS

Before plugging the Mixer Module into an outlet ensure that it is able to provide appropriate AC power.

A robust AC power supply is necessary for maximum performance. If the supply is too weak the bass performance may be affected and if it sags (drops) too much the system may self-mute to protect itself. As soon as the appropriate AC supply is restored it will continue to operate. Plugging multiple systems into the same outlet and long extension cord runs may affect the AC supply to the system.

CAUTION!

In compliance with safety agency criteria and proper system operation, it is critical that the system installer observe all electrical safety practices at all times and provide proper earth grounding for all AC Power connections.

POWER UP

The main power switch is located on the side of the mixer module where the AC cable attaches to the mixer.

SECTION 4: INTRODUCTION TO THE PA SYSTEM

Thank you for choosing our PA system. This portable PA system features multiple input channels with individual tone controls, convenient output routing capabilities that allow the user to integrate the system into any number of audio environments. And with its light weight it is perfect for situations where ease and portability are just as important as quality and flexibility.

- 2 Speakers with detachable modules
 - 1 module contains the powered mixer
 - 1 module is designed for storage of speaker cables
- 1 Pair of unshielded speaker cables (3M)
- 1 Power cable
- User's Guide

HOW TO ASSEMBLE

1. Remove the speakers, power cable and the speaker cables from the carton.
2. Detach the modules from the speakers. By pressing and sliding the button on the top of the speakers. You will release the module from the speaker. All that is required is a little lift on the module once the button is pressed (Ex.1)

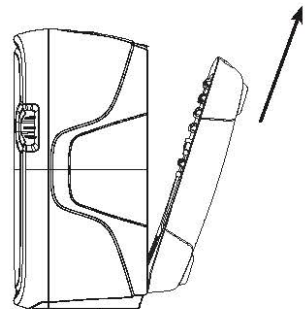
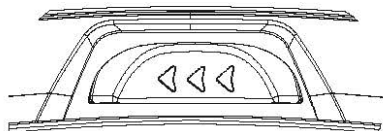
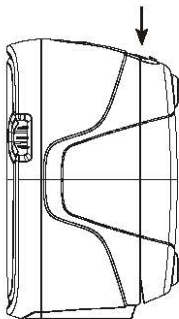

3. If you have purchased speaker stands, you can place the speakers on the stands utilizing the pole mount adaptor built into the speaker cabinets. Once the speaker is on the pole, tighten the set screw to snug the speaker to the pole.

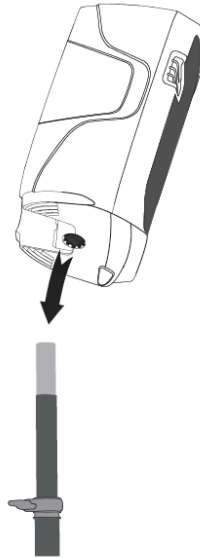

4. Connect the Mixer Module to the Speakers - On the right side of the mixer you will notice two 1/4" audio jacks - these are your speaker output jacks. Take the speaker cables and connect them from these jacks to the jacks on the back of the speakers.
5. Connecting the AC Power Cable - Connect the female end of the power cable to the mixer and plug the male end into the wall socket or extension cord. Turn the "MASTER VOLUME" control to "0". Now turn the power switch to the "on" position. You should see the "POWER" indicator illuminated. At this point you are ready to bring in an audio signal and hear the signal amplified by the system.

GETTING ACQUAINTED WITH THIS POWERED MIXER

This part of the system houses the mixing board and power amplifier. You will connect all of the microphones, musical instruments, external sound sources (like MP3 or CD players), headphones in addition to any recording devices or additional speakers like a personal monitor, subwoofer.

THE BASICS

While it looks complicated, the mixing board is actually a very simple device. A “mixing board” brings audio sources “in” (through the inputs) and routes the signal to the outputs (MASTER VOLUME/SPEAKER OUTPUTS or MONITOR OUTPUTS). The mixer controls enable the user to affect the tone and/or volume in addition to routing the signal and adding effects to individual input sources. The abundance of knobs is simply due to the repetitive nature of the design.

Let’s look at the “inputs” first:

AUDIO INPUTS

It has 10 inputs: 4 mono inputs and 2 stereo inputs, and USB and SD card input. All of the inputs will route to the speakers and to the MONITOR OUTPUT SECTION.

USB/SD INPUT & SCREEN INDICATE

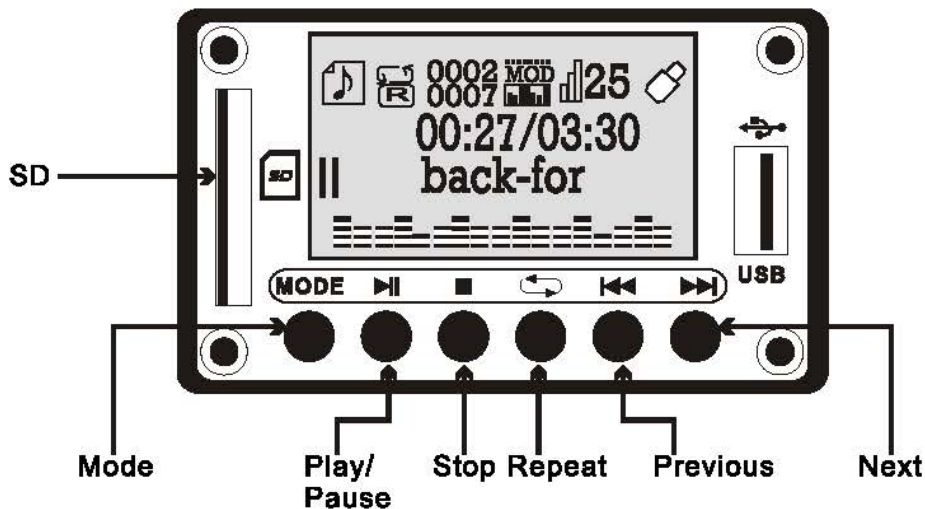

Key Function:
Mode, Play/Pause, Stop, Repeat, Previous, Next

Definition	Key Type	USB	SD	FM
Mode	Short Press	Switch device: FM-USB-SD-Bluetooth		
	Continuous Press	Power Off/ Power On		
Play/Pause	Short Press	Play or Pause Playing		Scan FM Channel Auto
Stop	Short Press	Stop Playing		Not defined
Repeat	Short Press	Select repeat mode ONE (repeat one), ALL (repeat one), RANDOM (random), INTRO (introduce)		Not defined
Previous	Short Press	Previous Song		Previous Channel
	Continuous Press	Fast Backward		Not defined
Next	Short Press	Next Song		Next Channel
	Continuous Press	Fast Forward		Not defined

BLUETOOTH

1. Using a mobile phone search Bluetooth device named as "BLUETOOTH"/
2. Connect Bluetooth, input ID coae:0000.
3. After connected, you can stream music from your phone to the system CS-2566 unit.

LCD DISPLAY INTRODUCTION

1. Playing Song in USB Memory

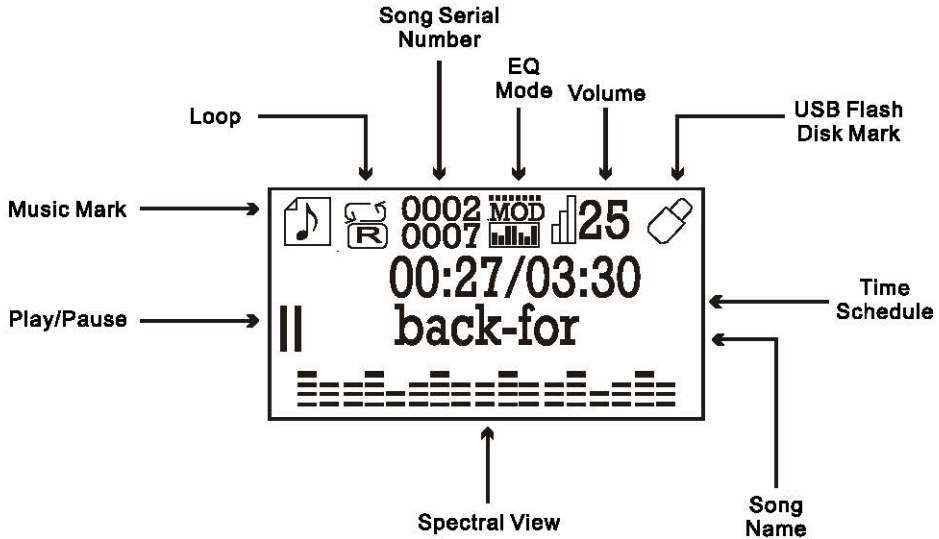

2. FM Status

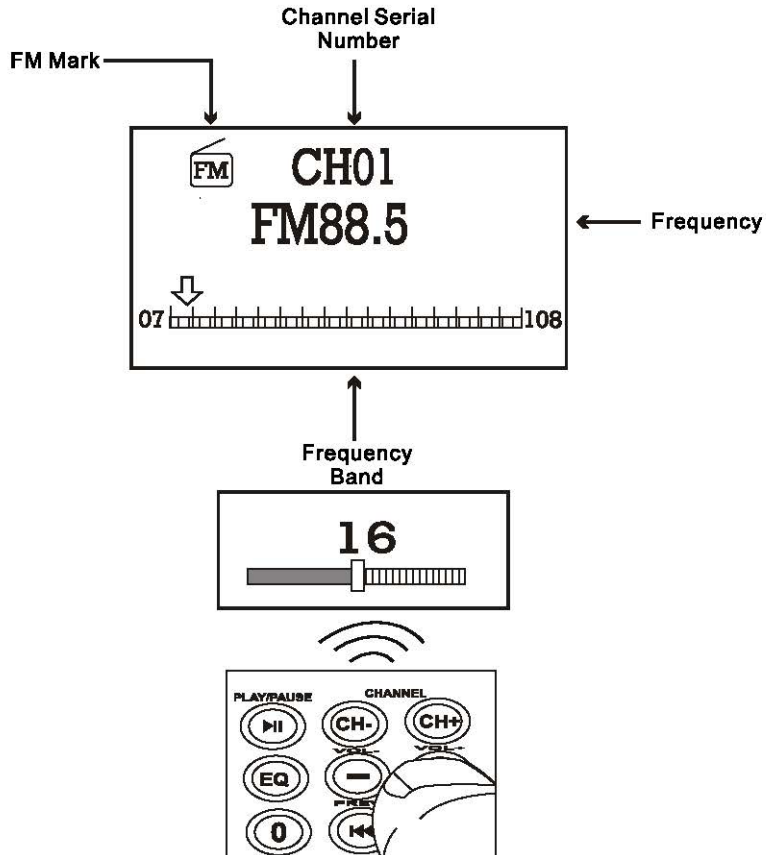

STEREO OUTPUTS: THE SYSTEM HAS 3 STEREO PAIRS OF OUTPUTS:

1. Left/Right Speaker Outputs - These outputs should only be connected to this system speakers and under no condition should they be connected to the input of another electronic device. These outputs carry power and as such could damage the electronic device. Only use “unshielded” speaker cables (like the cables provided).
2. “Monitor Outputs” - These outputs allow you to route the stereo mixer signal to another destination like a recording device, personal monitor, subwoofer or to another PA system (Front of House). Depending on the input connectors of the destination device, you can use either the 1/4” phone jacks or the RCA jacks.
 - A. Monitor Output Volume - This controls the overall volume of the monitor output.
3. Headphone Output - This output allows the user to listen to the main output the mixer. Headphones used will require a 3.5mm stereo plug.

MASTER VOLUME & “PEAK LED LADDER”

The system is equipped with a “Master Volume” that controls the overall output volume of the system and a 5 light “Peak LED Ladder” that gives you a visual display of how much power you are using (think of the speedometer on your car). The red or top LED on the ladder indicates that you are approaching the maximum output by blinking or, when it stays on constantly, indicates you have reached the maximum output. As a frame of reference if a channel volume is on “7” and the “Master Volume” is on “7” you will have reached the maximum output before distortion is audible.

DIGITAL EFFECTS

An effect on a vocal or instrument can create a very natural sense of space for the listener and is great fun for the performer. Used correctly, effects enhance a voice or instrument in a musical way but, when used to excess, they can make the music or voice less intelligible and unnatural. As a basic place to start turn the EFFECT control on the appropriate channel. Then select an effect that is suitable for your application. If there is too much effect then turn down the RETURN to suit your taste.

Located on each mono input strip is a control labeled "EFFECT". This control determines the amount of effect for that specific channel.

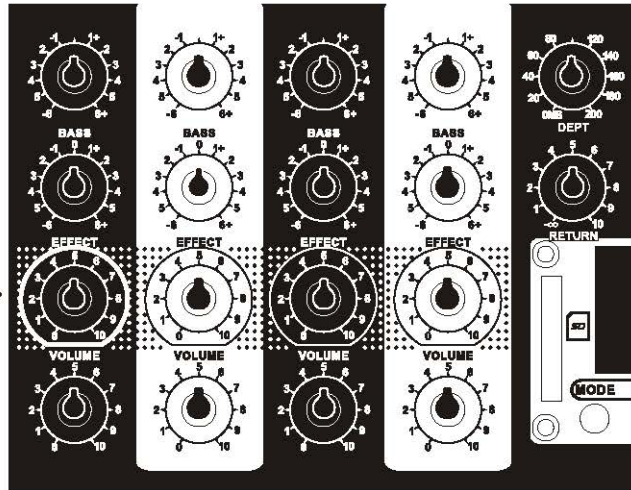

"DEPT"
Time delay and repeat effect.

The "RETURN" controls the amount of effect on a global basis. All channels that have the "EFFECT" control activated will be affected by turning this control up or down.

CONNECTING A MICROPHONE:

1. Turn the "Master Volume" to "0".
2. Connect the microphone or other device to mono 1/4" phone connector.
4. Set the "Treble" and the "Bass" control to "0" (In the center at the detent).
5. Set the "Reverb" to "0".
6. Line input/microphone voice control.
7. Slowly bring up the "Master Volume" to the desired loudness. *If you are using a "condenser microphone" engage the PHANTOM POWER button.

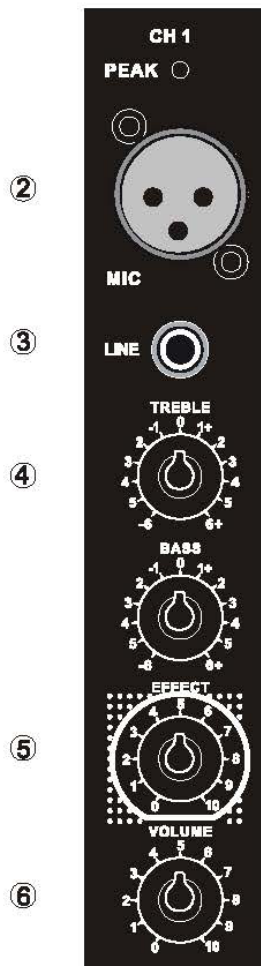
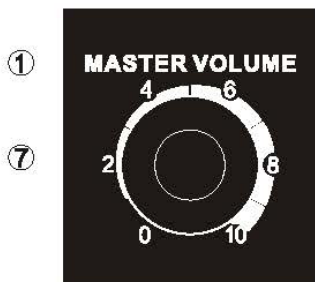

CONNECTING A KEYBOARD, DRUM MACHINE, CD OR MP3 PLAYER TO THE 5/6 STEREO INPUT:

- a. Turn down both the “Volume” control on channel “5/6” and the “Master Volume” control.
- b. Connect the output of the device to the “5/6” input of the mixer using the appropriate input jacks, (1/4” phone or RCA depending on the output of the device you are trying to connect)
- c. Bring up the “5/6” “Volume Control” to the 5-7 range.
- d. Slowly bring up the “Master Volume” to the desired loudness.

CONNECTING A PERSONAL MUSIC PLAYER TO THE 7/8 STEREO INPUT:

- a. Turn down the “Master Volume” control.
- b. Connect the output of the device to the “7/8” input of the mixer using a 3.5mm stereo “mini plug.”
- c. If there is an output gain or volume control on the device, set that to “7”. This level is a starting point but should get you enough output to drive the input of the system.
- d. Slowly bring up the “Master Volume” to the desired loudness.

USING THE MONITOR OUTPUTS

You can connect these outputs to a variety of devices like a recording device, a powered subwoofer, additional power amplifier and speakers or even another mixer.

- a. Turn the “Monitor Output Volume” control to “1”/
- b. Connect the “Monitor Outputs (Either the 1/4” Phone or RCA) to the inputs of the device into which you want to plug the mixer.
- c. Set the input level of the external device according to the manufacturer instructions.
- d. Slowly bring up the “Monitor Output Volume” to the desired loudness.

STORING

- a. Turn down the “Master Volume” control.
- b. Turn the mixer unit off.
- c. Disconnect the AC Power cable from the mixer and then unplug the cable from the wall outlet.
- d. Disconnect the speaker cables from the mixer and then disconnect the speaker cables from the speakers.
- e. Disconnect all other inputs (microphones, instruments or music players) from the mixer.
- f. Return the cables to the storage module and secure the latch.
- g. To return the storage module or mixer module back to their “attached” position on the rear of the speakers simply reverse the process described in the “Getting Started” Portion of the manual.

(1) Slide the module into the back of the speaker

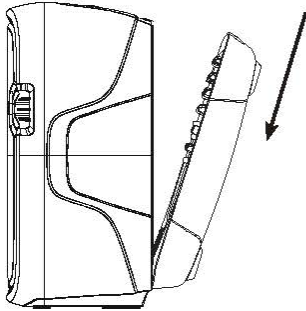

(2) Gently press forward and snap the module into the latch

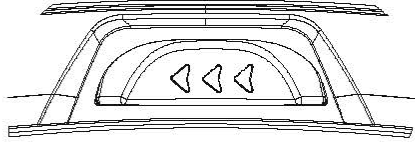

(3) The module should be securely fastened to the speaker and ready for transport

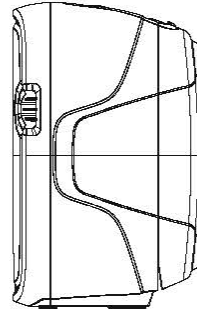

CAUTION!

The System was designed as a system and is to be used as such, The powered mixer will not function with speakers that have an impedance lower than 8 ohms.

SECTION 5: SYSTEM SPECIFICATIONS

System:	
System:	Type Powered mixer with 2 two-way bass-reflex enclosures
Maximum SPL Output:	115 dB peak system output
Frequency Range (-10 dB):	60Hz - 20kHz
Frequency Response (± 3 dB):	75Hz - 19hKz
AC Input:	120-240VAC @ 50-60Hz
Amplifier:	
Design:	Class B
System Power Rating:	100W (50W x 2)
Output Connector:	2 x 1/4" (unbalanced) amplifier outputs
Mixer:	
Input Connectors:	8 inputs (4 Mono Mic/Line, 2 x Stereo)
Mp3 Panel:	USB, SD input, FM bluetooth selectable

Channels:	1-4 are XLR / 1/4" jack connectors XLR microphone input 1/4" line input XLR is a mic level input, 1/4" is a line level input 5-6, one pair of 1/4" balanced TRS jacks (stereo), and a pair of RCA jacks (stereo) 7-8 is a 3.5mm stereo jack
Input Impedence:	Ch 1-4 Combo: XLR 3 K Ohms Balanced
Ch 1-4 Combo:	TRS 20kΩ Balanced
Ch 5-6:	TRS 25kΩ Balanced
Ch 7-8:	3.5mm 30kΩ Unbalanced
Phantom Power:	30V
Output Connectors:	Monitor outputs: One pair of 1/4" balanced TRS jacks (stereo), and a pair of RCA jacks (stereo)
Headphone output:	One 3.5mm stereo jack
Signal Indicators:	Limit: Red LED indicates limiter active condition Main Output LED Ladder Green LED Indicates signal present
Signal:	Ch 1-4 Peak LED: Green = signal present, Red=input overload
Signal Indicators:	
EQ:	Individual channel Bass and Treble controls, center detent, +/-6 dB
Speaker:	
System Limiter:	On Board DSP Limiting and Tuning
LF Driver:	38mm 30Oz, subwoofer
HF Driver:	34mm titanium
Crossover Frequency:	1.8kHz
Enclosure:	ABS
Suspension/Mounting:	36mm pole socket with stabilizing screw
Handles:	One on top
Net Weight of System:	18.5kg (for unit with power-mixer, 10kg for unit with storage pod 8.5kg)

SECTION 6: TROUBLE SHOOTING

Symptom	Likely Cause	What to Do
No Sound	No Power	Make sure that the AC cord is properly seated into the AC receptacle both at the wall outlet and on the mixer. Make sure the AC switch is in the "ON" position. If you are using an "AC Strip" check to see that it is working properly.
	Volumes are turned down	Make sure both the mixer's channel volume and master volume are turned up. Double check to see if the source volume is turned up.
	Mechanical connections are loose	Check to see if the input to the mixer is properly seated.
	Bad cables	Check the speaker connections to see if they plugged in all of the way.
	Phantom Power is off	If you are using a "Condensor" type microphone you will need to activate the "Phantom Power" switch for the microphone to work.
Sound is Distorted	Input overload	If the "Peak LED Indicator" is flashing red or on constantly you may be overloading the input.
		If you are using an external device like a personal music player or electronic instrument try lowering the volume on that device.
	System is overloading	Check the "System Level Indicator" LED's and if the "Limit" or red light at the top of the ladder is on constantly you may be over driving the system. Turn down the Master Volume.
Sound is thin	Too much treble	Check the channel's "Treble" control and turn it to the "0" position.
	Not enough bass	Check the channel's "Bass" control and turn it to the "0" position.
	Speakers not connected properly	Check the speaker connections to see if they plugged in all of the way.
	Effects levels may be too high	Try turning down the "Master Effects Return".
Sound is too boomy or dark	Not enough treble	Check the channel's "Treble" control and turn it to the "0" position.
	Too much bass	Check the channel's "Bass" Control and turn it to the "0" position.

Hum or Buzz that increases or decreases when the mixer level controls are moved	Improper A/C ground or faulty equipment connected to mixer input	Disconnect or mute channels one at a time to isolate the problem. Refer to the owner's manual of the faulty equipment for troubleshooting help.
	Faulty cable between source equipment and mixer	Substitute a known-good cable for the suspected faulty cable.
Hum or Buzz	Improper A/C grounding, ground loops	Try using a ground lift adaptor. Connect all power cords to the same power strip.
Noise or Hiss Heard at Output	Noisy source device	Disconnect the devices that are connected to your mixer one at a time. If the noise goes away, the problem is with the source or the connecting cable.
	Unused channel volumes are up too high	Lower the channel volume on unused channels to "0".
Feedback	Microphones are too close to the speakers	Speakers should be between the audience and the microphones in order to avoid feedback.
Headphone signal is weak	Monitor Output is turned down	Turn up the "Monitor Output Volume" on the mixer.
	Channel Input is too low	Make sure that the channel input volume is turned up.
	Impedance mismatch	Your headphones have too high of an impedance. Try a different set of headphones.

Distributed by:
Electus Distribution Pty. Ltd.
320 Victoria Rd, Rydalmere
NSW 2116 Australia

Ph: 1300 738 555
Int'l: +61 2 8832 3200
Fax: 1300 738 500

www.electusdistribution.com.au

Made in China



WARNING – KEEP BUTTON BATTERIES OUT OF REACH OF CHILDREN

- If swallowed a lithium button battery may lead to serious or fatal injury in as little as 2 hours, due to chemical burns and potential perforation of the oesophagus
- All button batteries must be kept away from children regardless if they are new or used.
- If you suspect your child has swallowed or inserted a button battery immediately call the 24-hour Poisons Information Centre on 13 11 26 (Australia) or 0800 764 766 (New Zealand) for fast, expert advice.
- If your child is having difficulty breathing contact 000 (Australia) or 111 (New Zealand).
- Dispose of used button batteries immediately and safely out of the reach of children. A battery can still be dangerous even when it can no longer operate the device.
- As soon as you have finished using a button battery, put sticky tape around both sides of it. This will make it harder for children to swallow the button battery and avoid the risk of the battery catching fire.
- Immediately dispose of button batteries immediately out of reach of children, or recycle using a child resistant container and take used cells to your local battery collection centre.